

# LMB-3 Bass Limiter Enhancer

## Owner's Manual

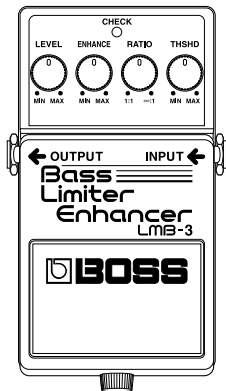

AC & BATTERY  
POWERED



**BOSS**

Thank you, and congratulations on your choice of BOSS LMB-3 Bass Limiter Enhancer. To ensure proper operation, and years of trouble-free service, please take the time to read through this Owner's Manual before starting out.

## FEATURES

- The BOSS LMB-3 is a limiter/enhancer specifically designed for electric bass.
- The LMB-3 allows you to create a well-balanced sound by controlling the volume difference of the sound or to avoid sound distortion.
- By adjusting the THRESHOLD level and RATIO knobs, the intensity of the limiter can be spontaneously controlled.
- Using the Enhance effect, you can make the sound clearer and sharper.

© 1995 BOSS Corporation

All right reserved. No part of this publication may be reproduced in any form without the written permission of BOSS Corporation.

## **IMPORTANT NOTES**

When using an AC adaptor, use only the specified device (PSA Series). Use of any other AC adaptor could result in damage, malfunction or electric shock.

### **POWER SUPPLY**

The power requirement for this unit is indicated on its nameplate (rear panel). Ensure that the voltage in your installation meets this requirement.

If the unit is to remain unused for an extended period of time, unplug the power cord.

### **PLACEMENT**

Do not subject the unit to temperature extremes (eg., direct sunlight in an enclosed vehicle). Avoid using or storing the unit in dusty or humid areas, or areas that are subject to high levels of vibration.

### **ADDITIONAL PRECAUTIONS**

Protect the unit from strong impact.

Should a malfunction occur, or if you suspect there is a problem, discontinue use immediately. Contact qualified service personnel as soon as possible.

To avoid the risk of electric shock, do not open the unit.

### **CHANGING BATTERY**

Remove the battery whenever the unit is to remain unused for an extended period of time.

# PANEL DESCRIPTIONS

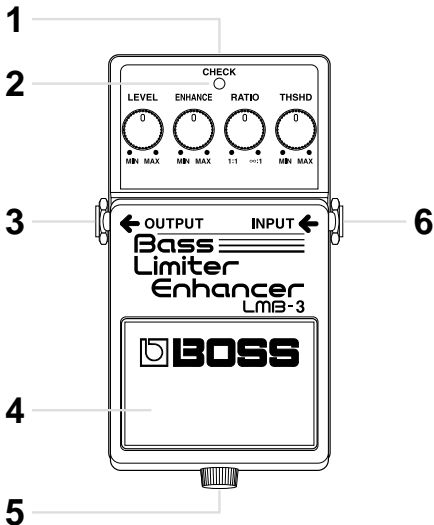

## 1. AC Adaptor Jack

Accepts connection of an AC Adaptor (optionally available BOSS PSA-Series). By using an AC Adaptor, you can play without being concerned about how much battery power you have left.

*\* You may find that it is a good idea to keep a battery installed in the unit even while using an adaptor. That way your playing won't be disrupted even if the adaptor is accidentally disconnected.*

*\* If you are going to use an AC adaptor, be sure to use the specified unit (BOSS PSA-Series). Use of any other adaptor may result in damage, malfunction or electric shock. Also, if you are not going to be using it for an extended period of time, disconnect the AC adaptor from the AC outlet.*

## 2. CHECK Indicator

This indicator shows whether an effect is ON/OFF, and also doubles as the Battery Check indicator.

The indicator lights when an effect is ON. If this indicator goes dim or no longer lights while an effect is ON, the battery is near exhaustion and should be replaced immediately.

## 3. OUTPUT Jack

The output jacks are used to connect the unit to amplifiers or other devices.

## 4. Pedal Switch

This switch turns the effects ON/OFF.

## 5. Thumbscrew

This thumbscrew is loosened to open the pedal, allowing battery replacement. For instructions on how to replace the battery, please refer to "CHANGING THE BATTERY".

## 6. INPUT Jack

This jack accepts input signals (coming from a bass guitar, some other musical instrument, or another effects unit).

*\* The INPUT Jack also serves as the power switch. Power is turned on whenever a plug is inserted into the INPUT Jack, and is turned off when the plug is disconnected. When not using the unit, you should disconnect any cord connected to the INPUT Jack.*

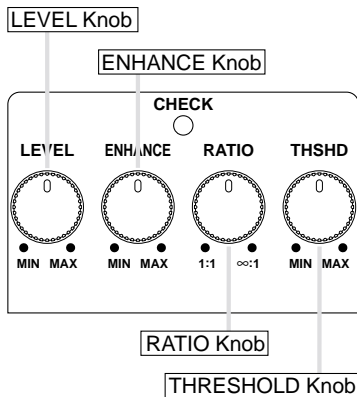

## LEVEL Knob

This knob adjusts the level of the effect sounds. Set the knob so there is no volume difference between the effect and straight guitar sounds.

*\* If this knob is rotated completely counterclockwise, no sound will be heard.*

## ENHANCE Knob

This knob adjusts the intensity of the enhance effect that makes the sound clearer and sharper. Rotating the knob clockwise emphasizes the effect.

## RATIO Knob

This knob controls the compression ratio of the limiter. That is, it adjusts how much the limiter should compress those signals above the threshold level.

*\* When it is set to "1:1", no limiter effect will be obtained.*

## THRESHOLD Knob

This knob controls the threshold level (the level at which the compression effect will kick in). Rotating the knob counterclockwise lowers the threshold level.

For a detailed explanation about the Ratio and Threshold Level, see "ABOUT THE LIMITER'S ACTION".

# MAKING THE CONNECTIONS

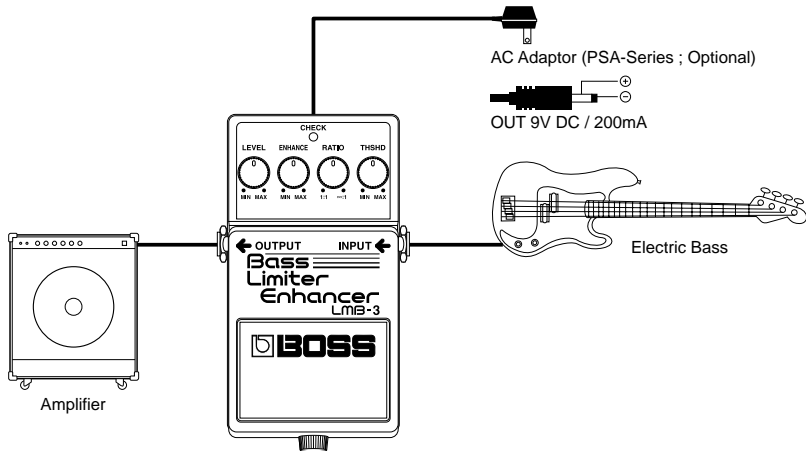

*\* Inserting a plug into the Input Jack will automatically switch the unit on.*

*\* Before connecting or disconnecting any patch cords, be sure all the volume controls in your system are set to minimum. This will help prevent any damage to system components.*

## OPERATING THE UNIT

1. When you have made the necessary connections, set the knobs as shown in the illustration.
2. Depress the pedal switch to turn the effect on. (Make sure that the CHECK Indicator lights.)
3. Adjust the Threshold Level (the level at which compression starts) using the THRESHOLD Knob.
4. Adjust the compression ratio using the RATIO Knob.
5. Adjust the intensity of the enhance effect using the ENHANCE Knob.
6. Adjust the LEVEL Knob so there will be no volume difference between the effect and straight bass sounds.

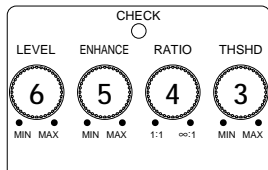
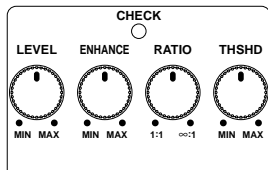



## ABOUT THE LIMITER'S ACTION

The LMB-3's limiter will function differently depending upon how you set the Ratio and Threshold Levels. The RATIO and THRESHOLD knobs work as described below.

**RATIO :** The compression ratio for the input signal is called Ratio. For instance, when the Ratio is set to "2:1", an input signal that is 6 dB louder than the Threshold Level will be compressed to one half, or 3 dB. When it is set to " $\infty$ :1", any input signal above the Threshold Level will be compressed to the Threshold Level, then output.

**THRESHOLD :** The Threshold Level is the level at which compression starts to work. When the input signal has reached the Threshold Level, the signal will be compressed at the compression ratio set with "RATIO", then output. When the input signal is lower than the Threshold Level, it will be output without compression.

The following figure shows how the output signal is affected by the settings of the RATIO and THRESHOLD knobs.

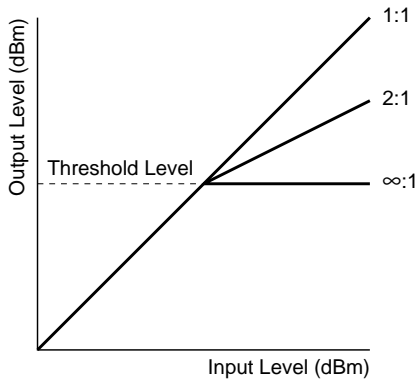
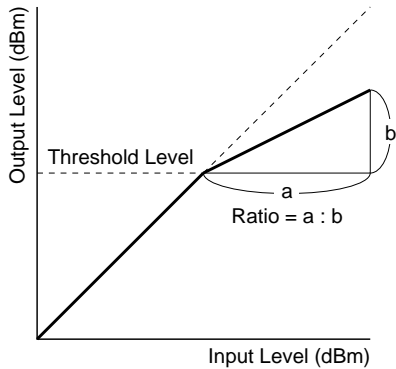

# CHANGING THE BATTERY

When the indicator goes dim or no longer lights while an effect is on, it means that the battery is nearly dead and must be replaced.

Replace the battery following the steps below.

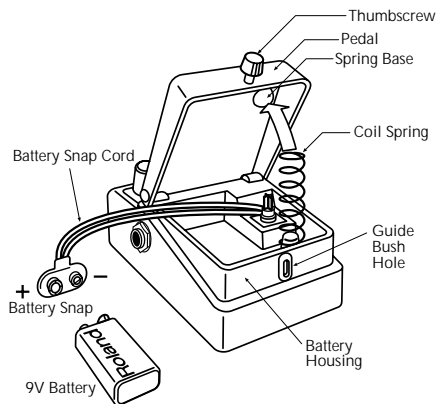

1. Loosen the thumbscrew at the front of the pedal, then lift the pedal upwards to open the unit.

*\* The thumbscrew can be left in the pedal while changing the battery.*

2. Remove the old battery from the battery housing, and remove the snap cord connected to it.

3. Connect the snap cord to the new battery, and place the battery inside the battery housing.

*\* Be sure to carefully observe the battery+ polarity (+ versus -).*

4. Slip the coil spring onto the spring base on the back of the pedal, then close the pedal.

*\* Carefully avoid getting the snap cord caught in the coil spring.*

5. Finally, insert the thumbscrew into the guide bush hole and fasten it securely.

# SAMPLE SETTING

## Limiter

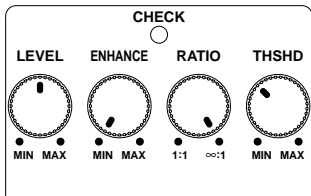

## Enhancer

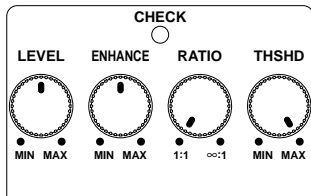

## Finger Picking

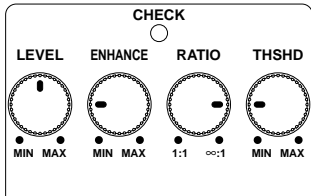

## Slapping Play

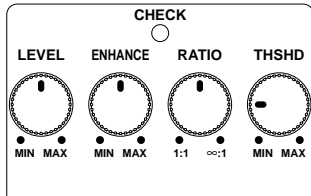

# SETTING MEMO

---

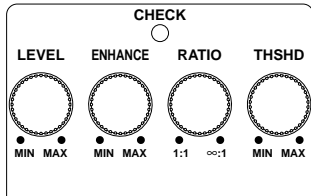
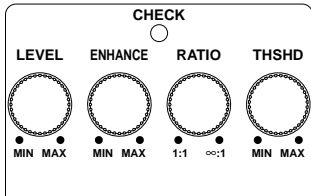
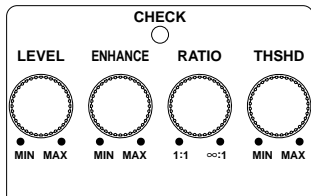
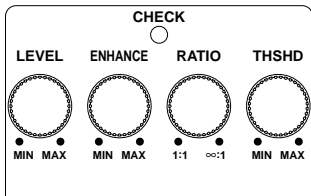

# SPECIFICATIONS

LMB-3 : Bass Limiter Enhancer

Nominal Input Level .....	-20 dBm
Input Impedance .....	1 M $\Omega$
Nominal Output Level .....	-20 dBm
Output Impedance .....	1 k $\Omega$
Recommended Load Impedance	10 k $\Omega$ or greater
Residual Noise Level .....	-86 dBm (IHF-A, Typ.)

Controls .....	Pedal Switch, LEVEL Knob, ENHANCE Knob, RATIO Knob, THRESHOLD Knob
Indicator .....	CHECK Indicator (serves also as battery check indicator)
Connectors .....	INPUT Jack, OUTPUT Jack, AC Adaptor Jack (9 V DC)
Power Supply .....	9 V DC : Dry Battery 9 V type (6F22/9 V), AC Adaptor
Current Draw .....	17 mA (9 V DC)

**\* *Expected battery life under continuous use :***

Carbon : 12 hours

These figures will vary depending on the actual conditions of use.

<b>Dimensions</b> .....	70 (W) x 125 (D) x 55 (H) mm 2-3/4 (W) x 4-15/16 (D) x 2-3/16 (H) inches
<b>Weight</b> .....	430 g / 15 oz (including battery)
<b>Accessories</b> .....	Owner's Manual, Dry Battery 9 V type (6F22/9 V), Roland Service
<b>Options</b> .....	AC Adaptor PSA-Series

*\* 0 dBm = 0.775 V rms*

*\* In the interest of product development, the specifications and/or appearance of this unit are subject to change without prior notice.*



**For EU Countries**  
This product complies with the requirements of  
European Directive 89/336/EEC.

 **BOSS**

00678767