



Copyright 2017, v1.1

## Q8x Professional Vocal Microphone

Thank you for purchasing the Samson Q8x Professional Dynamic Vocal Microphone. The Q8x microphone brings a high level of accuracy and clarity to your audio performance and vocal miking applications.

The Q8x is a hand held dynamic microphone that excels both on the stage and in the recording studio. Thanks to its neodymium magnet and lightweight diaphragm, the Q8x provides a linear frequency response for superior reproduction, with the capability to withstand high sound pressure levels. It employs a tight supercardioid pattern to reduce feedback as well as a pneumatic shock-mounted element that minimizes handling noise and provides additional protection.

With proper care and maintenance, your microphone will operate trouble-free for many years. Should your microphone ever require servicing, a Return Authorization (RA) number must be obtained before shipping your unit to Samson. Without this number, the unit will not be accepted. Please visit [www.samsontech.com/ra](http://www.samsontech.com/ra) for an RA number prior to shipping your unit. We recommend retaining the original packing materials and, if possible, return the unit in its original carton. If your microphone was purchased outside of the United States, contact your local distributor for warranty details and service information.

If you have any questions or comments do not hesitate to contact us at [support@samsontech.com](mailto:support@samsontech.com).

## Proximity Effect

Unidirectional microphones, exhibit a phenomenon known as “proximity effect.” Very simply put, proximity effect is a resulting change in the frequency response of a microphone based on the position of the microphone capsule relative to the sound source. Due to the result of the proximity effect, slight adjustments of the microphone position and angle can make a big difference in sound. Specifically, when you point the microphone directly at the sound source (on axis) you will get the best frequency response, however when you start pointing the microphone slightly away (off axis) you will notice the low frequency response dropping off and the microphone will start to sound thinner.

The Q8x will boost bass frequencies when the microphone is between 0 – 2 inches from the sound source. As you move the sound source further away from the microphone, the bass response will gradually roll off.

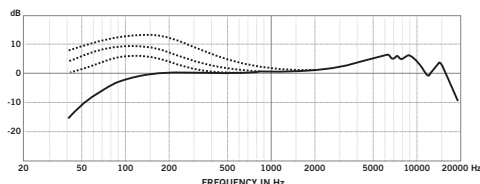

## Features

- Dynamic mic element with neodymium magnet provides an extended range frequency response for optimum reproduction and exceptionally clear, crisp sound.
- Ultra sensitive element picks up all of the nuances of any performance
- Frequency response tailored for vocal performance with a mid-range lift and low-frequency roll off.
- Tight supercardioid polar pattern minimizes feedback problems and effectively rejects signals not originating directly in front of the mic capsule.
- Able to withstand high SPLs (Sound Pressure Levels) lending itself to a wide range of miking situations
- Special pneumatic shock-mounting greatly reduces handling noise.
- Rugged zinc alloy die-casting case ensures reliable performance in even the most demanding environments.
- Gold plated XLR Connector
- Includes a zipper carry pouch and mic clip.

## Microphone Placement Guidelines

Listed are some common microphone placement techniques. Use these suggestions as a guide and let your ears determine what works best in your situation.

- Sound source less than 6 inches away from mic — Full sound, pronounced bass, increased isolation from background noise.
- Sound source 6 inches to 2 feet away from mic — Balanced natural sound, less bass, some background noise.
- Sound source 3 to 6 feet away from mic — Thinner ambient sound.
- Aim the microphone at the desired source. Keep unwanted sound sources at a 135° angle from the front of the microphone.
- Place the microphone as close to the sound source as possible.
- Utilize the 3 to 1 Rule when positioning microphones. A microphone should be placed at least three times the distance from other microphones as it is from the sound source.
- Never cup your hand over the microphone grill as it can change the performance characteristics of the microphone and may cause undesired effects to the audio.

## Polar Pickup Pattern

Every microphone has a characteristic polar pattern that determines how well it accepts or rejects signal coming from various areas around the microphone. For example, omnidirectional mics accept all signals regardless of wherever those signals originate (in front of the mic, behind it, to the side, etc.). In contrast, directional cardioid mics are specifically designed to accept mostly coming from directly in front, and to reject signal coming from behind or from the side. The Q8x has a supercardioid pattern, which is a variation of the standard cardioid pattern with a slightly tighter pick-up pattern that helps increase the side-to-side rejection. For this reason, the Q8x excels in environments where there is a good deal of unwanted ambient sound (like a live sound stage) as it deliver signals originating directly in front of the mic capsule itself while rejecting those that originate from behind.

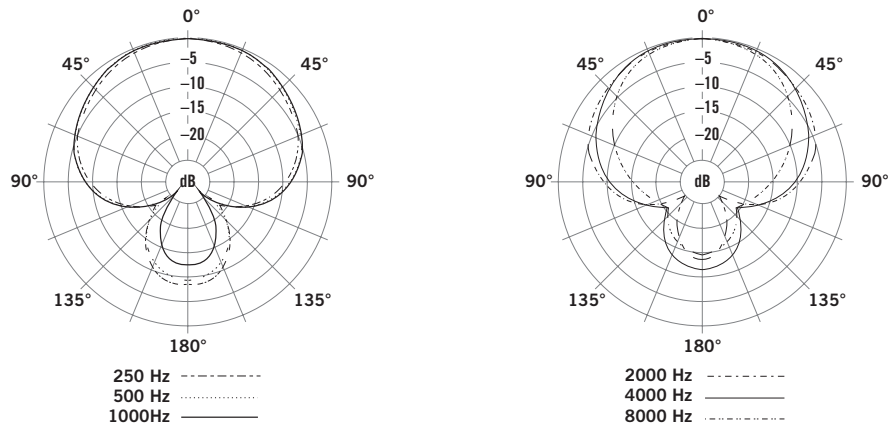

## Frequency Response

The Q8x microphone has been designed with a frequency response that has been tailored for vocal performance with a slight lift in the mid-range and a low end roll-off. The Q8x also excels at miking instruments and speaker cabinets. The response is created by the careful consideration of the microphone element and the design of the capsule porting.

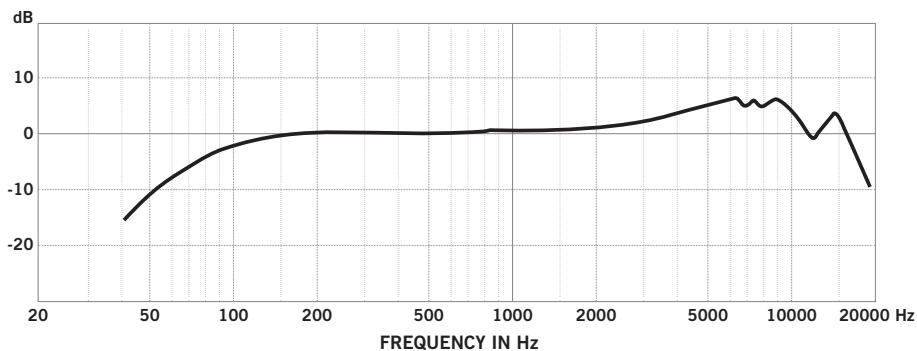

## Wiring

The Q8x can be connected to any type of equipment that has a microphone preamp using a standard microphone cable. As shown in the wiring diagrams below, connect the female XLR end directly to the Q8x's gold-plated connector and the other end to the microphone input.

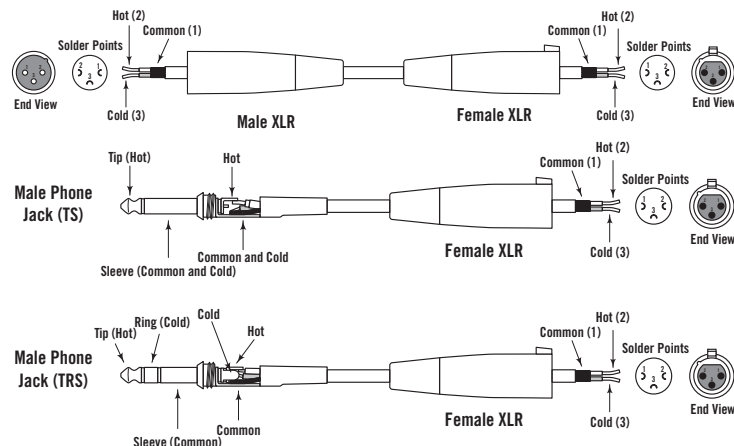

## Specifications

Element	Dynamic
Magnet structure	Neodymium
Frequency Response	50 Hz – 16 kHz
Polar Pattern	Supercardioid (unidirectional)
Impedance	300 ohms balanced (low-Z)
Sensitivity	-54 dBV/pa (2.5 mV/pa)
Max SPL	150 dB SPL
Microphone Connector	3-pin, XLR-type
Polarity	Positive pressure on diaphragm causes positive voltage on pin 2 ref. Pin 3
Accessories	Mic clip, zipper pouch
Dimensions	7.09" x 2.125" (180mm x 54mm)
Weight	0.97lb (0.44kg)