

1

Check the included items

As soon as you open the package, check to see that all items are included. If anything is missing, please contact your dealer.

TD-27KV (Drum Set)

- TD-27 (Drum sound module) x 1
- PD-140DS (V-Pad digital snare) x 1
- CY-18DR (V-Cymbal digital ride) x 1
- VH-10 (V-Hi-hat) x 1
- KD-10 (Kick Pad) x 1
- PDX-100 (V-Pad) (tom1, 2, 3) x 3
- CY-12C (V-Cymbal for crash 1) x 1
- CY-13R (V-Cymbal for crash 2) x 1

Owner's Manuals

- TD-27KV Setup Guide (this document)
 - TD-27 Quick Start
 - PD-140DS Owner's Manual
 - CY-18DR Owner's Manual
 - VH-10 Owner's Manual
 - KD-10 Owner's Manual
 - PDX-100 Owner's Manual
 - CY-13R / CY-12C Owner's Manual
- * The TD-27/PD-140DS/CY-18DR accessories are in the respective packing cartons.

Cables

- Dedicated connection cable x 1 (Packed with the TD-27)
- Trigger cable x 1
- Connection cable x 2 (Packed in the respective cartons of the PD-140DS and CY-18DR)

MDS-Standard 2 (Drum Stand)

- * When checking the items included with the drum stand, refer to "MDS-Standard 2 Owner's Manual."

* This package does not include a kick pedal, a hi-hat stand, and a snare stand. Use with a commercially available kick pedal, hi-hat stand, and snare stand.

* The drum key used to attach the pads is inside the packing carton of the drum sound module.

2

Assemble the drum stand (MDS-Standard 2)

Assembly procedure

Assemble the drum stand using the procedure described in "MDS-Standard 2 Owner's Manual."

* This drum set illustration is for a right-handed player. If you want to set up for a left-handed player, assemble it as described in "Assembly for a left-handed player" in "MDS-Standard 2 Owner's Manual."

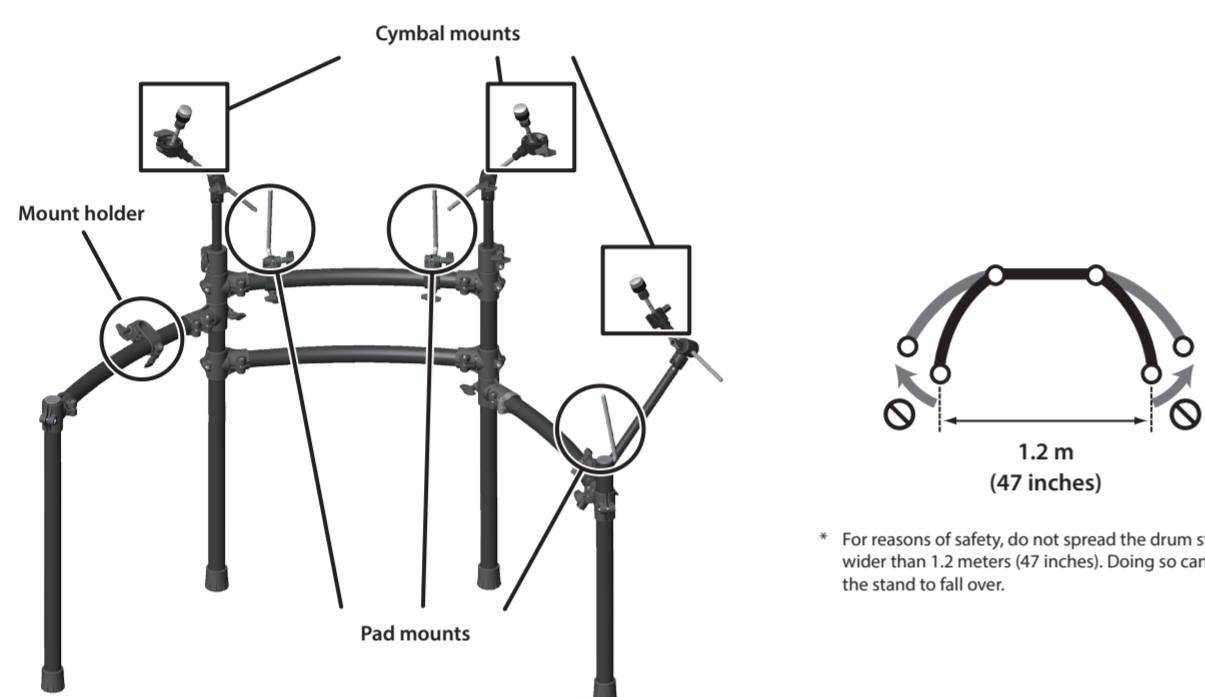

3

Assembling the Hi-Hat (VH-10)

Assembly procedure

1. Remove the clutch included with the hi-hat stand (commercially available) from the cymbal rod.

* The clutch included with the hi-hat stand will not be used.

* It is not necessary to remove the felt component (or rubber portion) on the hi-hat stand used for supporting the bottom cymbal.

2. Confirm that the cymbal rod is firmly secured.

For instructions on tightening the cymbal rod, refer to the owner's manual for your cymbal stand.

* Looseness or play in the cymbal rod can make the top hi-hat unstable, causing it to shake or turn, and prevent proper functioning.

3. With the sponge surface of the anti-vibration plate facing upward, pass it over the cymbal rod.

This will rest on top of the felt component (or rubber portion) of the hi-hat stand's cymbal receiver.

4. Place the motion sensor unit with the cymbal rod passing through the hole of the motion sensor unit.

* Position the CONTROL OUT jack on the farther side, as viewed from the player.

5. Pass the hi-hat over the cymbal rod.

Positioning the "Roland" logo on the farther side, as viewed from the player will provide the best sensitivity.

6. With the hi-hat completely separated from the motion sensor unit, power-on the TD-27.

* When turning the VH-10 upside down, protect the clutch and the sensor from damage. Handle the unit with care so that it is not dropped or overturned.

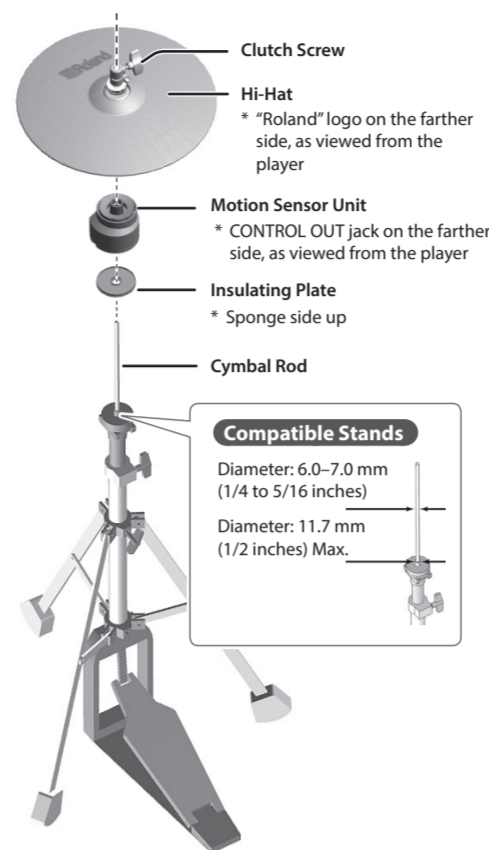

Reference

For details on the hi-hat, refer to "VH-10 Owner's Manual."

4

Assembling the Kick (KD-10)

Assembly procedure

1. Attach the kick pedal (commercially available) to the KD-10.

Position the beater so that it strikes the center of the head, then secure the kick pedal and KD-10 firmly in place.

* Take care not to pinch your fingers.

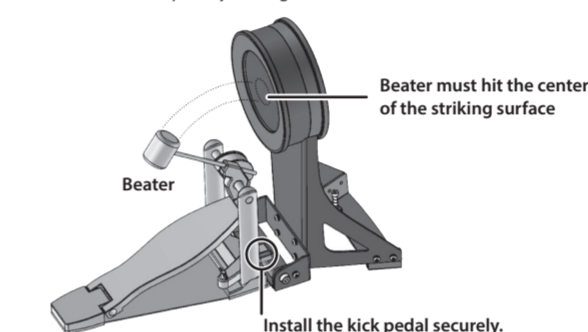

Reference

For details on the kick, refer to "KD-10 Owner's Manual."

2. Step on the kick pedal and make sure that it's properly attached and in a stable position.

Check to make sure that the KD-10 and the kick pedal both make contact with the floor.

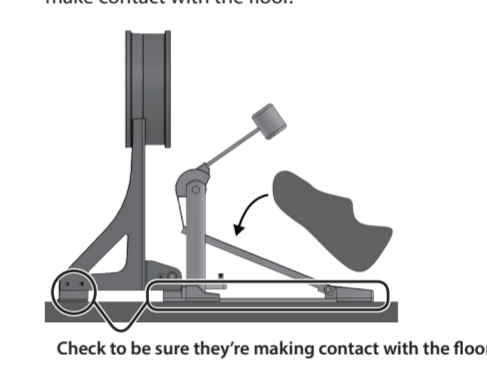

5

Attaching Various Parts to the Drum Stand

Use the included drum key to attach the various parts.

* The settings explained in this guide are for a right-handed player. If you want to set up for a left-handed player, refer to "Assembly for a Left-Handed Player" in the next page.

* For details on each part, refer to the owner's manual of each part.

Attach the drum sound module (TD-27)

1. Use the included wing bolts to attach the sound module mounting plate to the drum sound module.

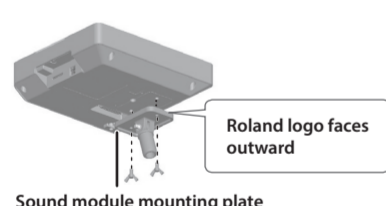

2. Loosen the hand knob of the drum stand mount holder, and insert the sound module mounting plate.

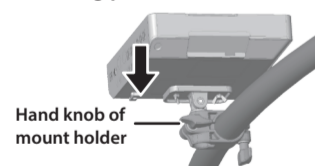

3. Using the drum key included with the drum sound module, adjust the angle of the sound module mounting plate.

Installing the hi-hat (VH-10)

Position it so that the Roland logo on the farther side, as viewed from the player.

Adjusting the position of the cymbal

Adjust the height of the rod so that the highest point of the cymbal is less than 1.2 meters (47 inches).



Attach the cymbal so that its center does not extend toward the back beyond the pipes of the stand (the pipes at the back of the stand).

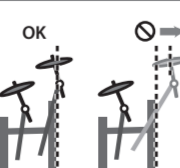

Attach the crash cymbal (CY-12C / CY-13R) and ride cymbal (CY-18DR)

1. Position the cymbal so that the convex portion of the cymbal mount is aligned with the concave portion of the bottom of the cymbal.

2. Tighten the cymbal nut to obtain an appropriate amount of sway.

* Use the cymbal nut and felt washer that are included with the drum stand.

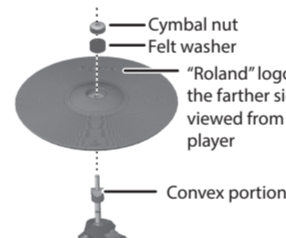

Insert the plug of the connection cable into the CY-18DR's DIGITAL TRIGGER OUT connector.



Attach the toms (PDX-100)

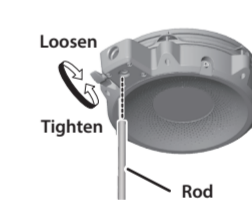

Adjusting the head tension

Adjust the tension so that the pad responds to your strikes with the appropriate feel.

* Before using the pad, tighten the head so that the tension is rather firm.

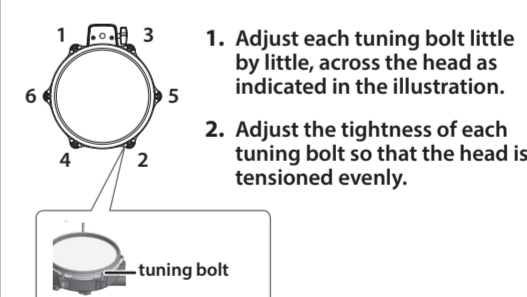

NOTE

Adjusting the head tension affects only the head response, and does not change the pitch of the sound as it would on an acoustic drum.

Pitch adjustments are made by editing the sound in your drum sound module. For details, refer to the "TD-27 Quick Start."

Mounting the snare (PD-140DS) on a snare stand

The PD-140DS can only be used with a commercially available snare stand.

* Make sure that the snare stand you are using is able to support a 14-inch shell.

Insert the plug of the connection cable into the PD-140DS's DIGITAL TRIGGER OUT connector.

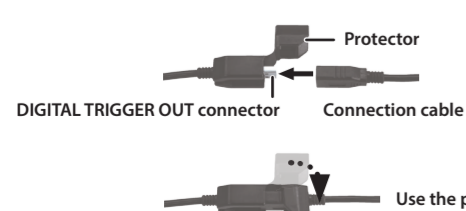

Adjusting the head tension

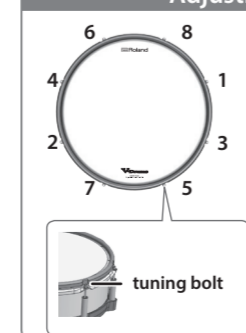

Adjust the tension so that the pad responds to your strikes with the appropriate feel.

1. Adjust each tuning bolt little by little, across the head as indicated in the illustration.
2. Adjust the tightness of each tuning bolt so that the head is tensioned evenly.

Installing the kick (KD-10)

If you're using this unit on a V-Drums mat, on a Noise Eater (NE-10), or on carpet, extending the anchor bolts will secure the unit in place, making it easier for you to perform.

* When used on flooring, the anchor bolts may damage the floor.
* The tips of the anchor bolts are sharp. Handle with care.

Adjusting the anchor bolts

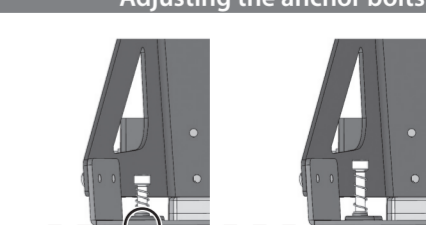

6 Connect the pads to the drum sound module

* To prevent malfunction and equipment failure, always turn down the volume, and turn off all the units before making any connections.

Connection procedure

- Connect the dedicated connection cable to the TRIGGER INPUT connector on the bottom panel of the drum sound module. Insert the connector all the way, then turn the knobs to fasten it securely.
- Labels indicating the pad to be connected are attached to the cable. Connect the cable to the OUTPUT jack of each pad as shown in the illustration at right.

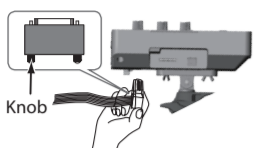

- Using the included trigger cable, connect crash 2 to the CRASH 2 jack of the TRIGGER IN jack on the back panel of the drum sound module.
- Using the included connection cables, connect the snare (PD-140DS) and ride (CY-18DR) to the DIGITAL TRIGGER IN ports of the drum sound module.

* The CY-13R is used as the crash cymbal. Bell shots are not possible.

* You may connect to any of the ports 1-3.

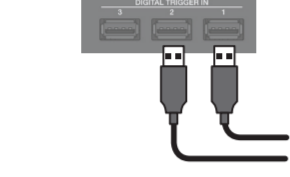
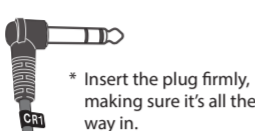
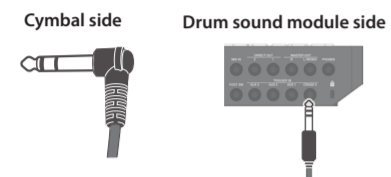

KIK CR1 Labels attached to the end of the cable

Dedicated connection cable

Trigger cable (Crash 2)

Connection cable (Snare, Ride)

Fasten the cables so that they will not obstruct your playing; use cable clips and cable ties. Make sure to wrap the cable ties around the pipes.

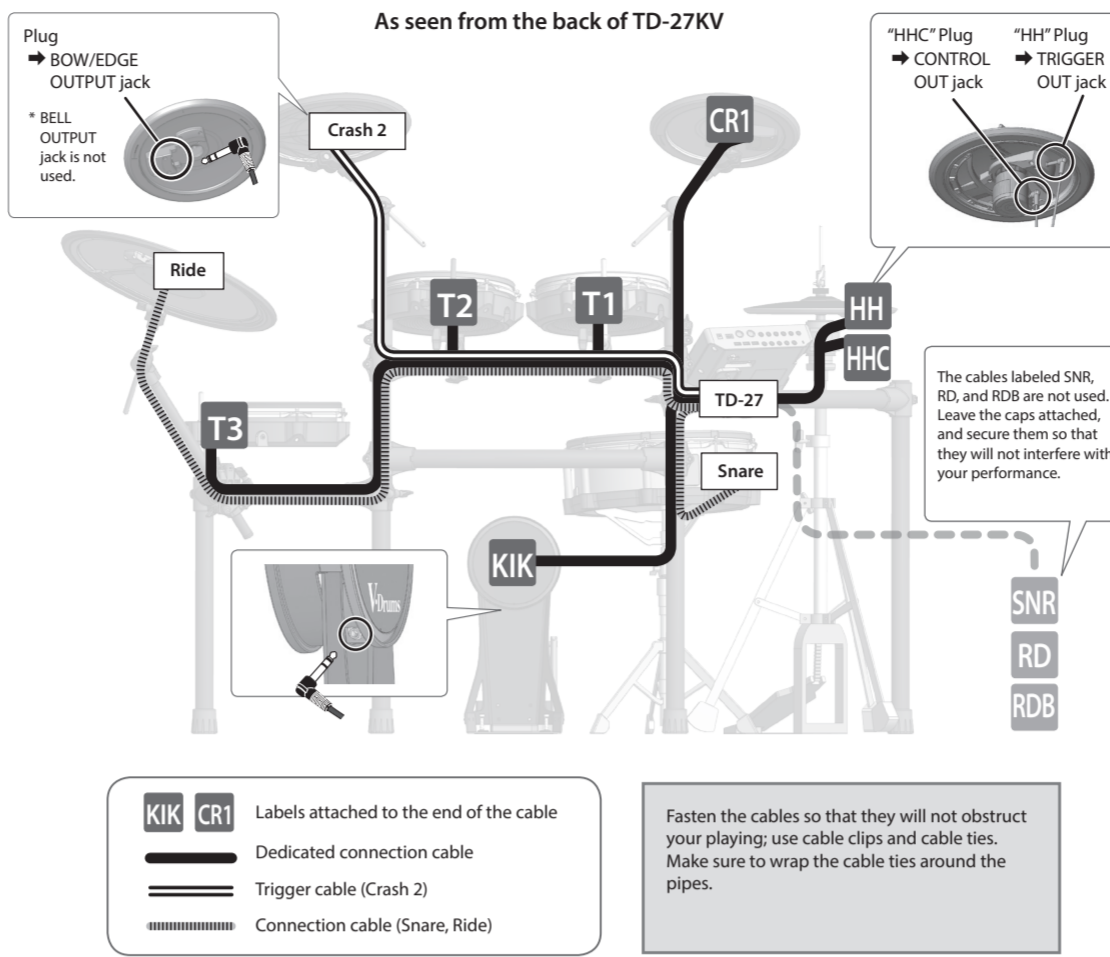

7 Connect the AC adaptor and speakers

* To prevent malfunction and equipment failure, always turn down the volume, and turn off all the units before making any connections.

Connect the AC adaptor, headphones, or speakers.

* Use the cord hook located on the bottom of the unit to secure the AC adaptor cord as shown in the illustration.

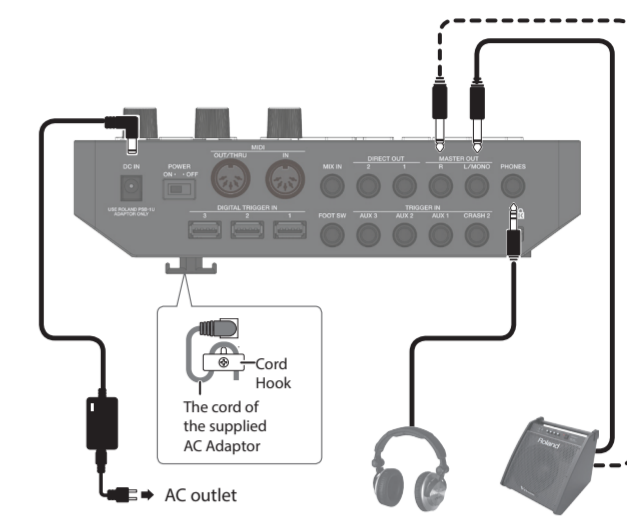

Assembly for a Left-Handed Player

The settings explained in this guide are for a right-handed player. If you want to set up for a left-handed player, assemble the drum stand according to the procedure described in “Assembling the stand for a left-handed player” in the “MDS-Standard 2 Owner’s Manual.” Also, install the pads as shown in the Figure A.

- Connect the cables to the OUTPUT jack of each pad as shown in the Figure B.
- Using the included trigger cable, connect crash 2 to the CRASH 2 jack of the drum sound module.

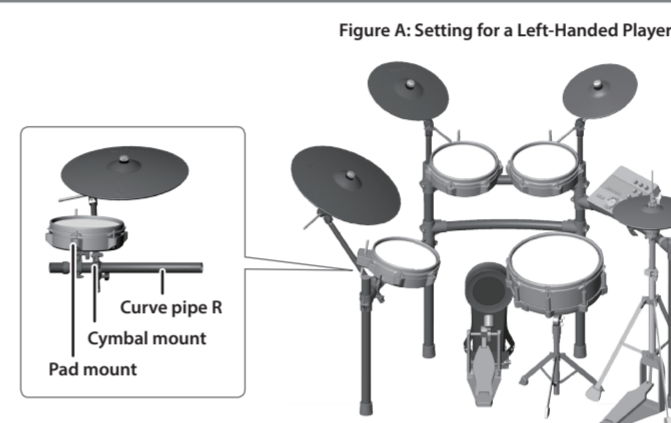
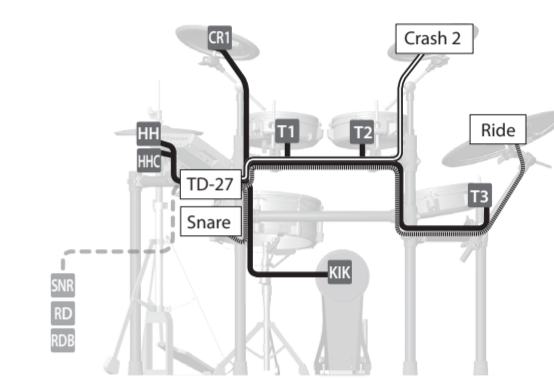

Figure B: As seen from the back of TD-27KV



This completes assembly and connections.

When you’ve finished making connections, turn on the power as described in “TD-27 Quick Start,” and verify that you can hear sound.

Set the snare (PD-140DS) and the ride (CY-18DR)

The first time you connect the PD-140DS and CY-18DR to the DIGITAL TRIGGER IN port, the following screen will appear. As directed in the screen, assign the PD-140DS as snare, and assign CY-18DR as ride.



* If you specify the same trigger input as a pad that is connected to a dedicated connection cable or TRIGGER IN jack, the pad that's connected to that TRIGGER INPUT jack and TRIGGER IN jack won't produce sound.

- Use the cursor buttons to select “OK,” and press [ENTER] button.

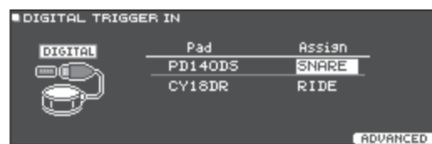

- Use the cursor buttons to select “PD140DS” or “CY18DR.”

- Use the dial to specify the Assign.

* You can't specify the same assignment multiple times.

Setting example

Pad	Assign
PD-140DS	SNARE
CY-18DR	RIDE

- Press the [DRUM KIT] button to return to the DRUM KIT screen.

This completes settings.

Adjust the hi-hat (VH-10)

If you're using the VH-10 V-hi-hat, execute the offset adjustment from the TD-27 after making connections. This adjustment is required for pedal movements such as open or close to be detected correctly.

- With the hi-hat completely separated from the motion sensor unit, power-on the TD-27.

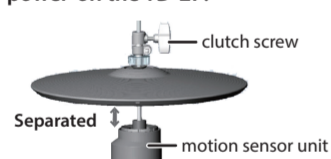

- Loosen the clutch screw and let the hi-hat rest naturally on the motion sensor unit.

- Press the [SYSTEM] button.

- Use the cursor buttons to select “TRIGGER,” and press the [ENTER] button.

- Use the cursor buttons to select “HI-HAT,” and press the [ENTER] button.

The TRIGGER HI-HAT screen appears.

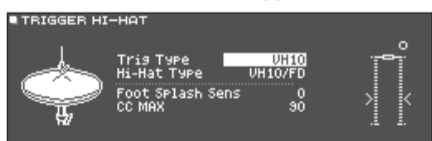

- Use the dial to set the Trig Type to “VH10.”

- While reading the meter displayed on the right side of the TD-27's screen, adjust the offset with the VH-10's offset adjustment screw.

Adjust the offset so that the ▶ appears in the meter.

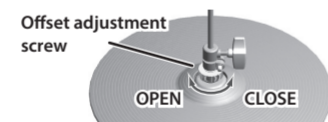

- Fasten the clutch screw at a position where the hi-hat sways naturally when struck.

- Press the [DRUM KIT] button to return to the DRUM KIT screen.

If you find the closed hi-hat sound difficult to play, turn the offset adjustment screw toward “CLOSE.”
If you find the open hi-hat sound difficult to play, turn it toward “OPEN.”
* If the sound is interrupted when you play a strong strike, adjust the offset adjustment screw toward “OPEN.”

Fixing the hi-hat cables

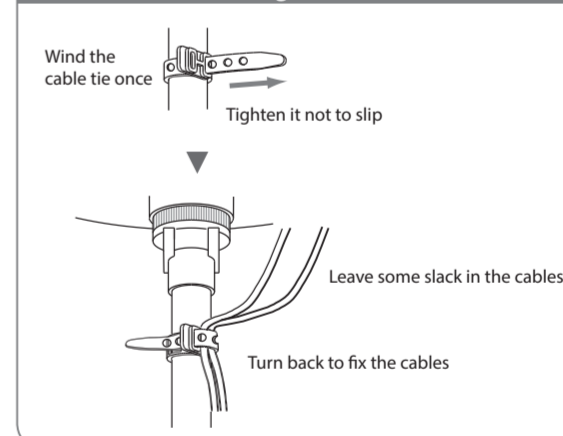

NOTE

- Continuous playing may cause discoloration of the pad, but this will not affect the Pad's function.
- If the hi-hat clutch has been detached from the hi-hat, refer to “If the Clutch Was Apart from the HI-Hat” in the “VH-10 Owner’s Manual.”

USING THE UNIT SAFELY

INSTRUCTIONS FOR THE PREVENTION OF FIRE, ELECTRIC SHOCK, OR INJURY TO PERSONS

About ⚠ WARNING and ⚡ CAUTION Notices

- WARNING** Used for instructions intended to alert the user to the risk of death or severe injury should the unit be used improperly.
- CAUTION** Used for instructions intended to alert the user to the risk of injury or material damage should the unit be used improperly.

About the Symbols

- The ⚠ symbol alerts the user to important instructions or warnings. The specific meaning of the symbol is determined by the design contained within the triangle. In the case of the symbol at left, it is used for general cautions, warnings, or alerts to danger.
- The ⚡ symbol alerts the user to items that must never be carried out (are forbidden). The specific thing that must not be done is indicated by the design contained within the circle. In the case of the symbol at left, it means that the unit must never be disassembled.
- The ⚙ symbol alerts the user to things that must be carried out. The specific thing that must be done is indicated by the design contained within the circle. In the case of the symbol at left, it means that the power-cord plug must be unplugged from the outlet.

ALWAYS OBSERVE THE FOLLOWING

- WARNING**
- Use only the stand that is recommended. This unit should be used only with a stand (MDS-Standard 2) that is recommended by Roland.
 - Do not place in a location that is unstable. When using the unit with a stand (MDS-Standard 2) recommended by Roland, the stand must be carefully placed so it is level and sure to remain stable. If not using a stand, you still need to make sure that any location you choose for placing the unit provides a level surface that will properly support the unit, and keep it from wobbling.

- WARNING**
- Be cautious to protect children from injury. Always make sure that an adult is on hand to provide supervision and guidance when using the unit in places where children are present, or when a child will be using the unit.
 - Take care not to get burned. Otherwise, you risk causing damage or malfunction.

- CAUTION**
- Use only the specified stand(s). This unit is designed to be used in combination with specific stands (MDS-Standard 2) manufactured by Roland. If used in combination with other stands, you risk sustaining injuries as the result of this product dropping down or tipping over due to a lack of stability.

- CAUTION**
- Take care so as not to get fingers pinched. When handling the following moving parts, take care so as not to get fingers, etc., pinched. An adult should always be in charge of handling these items.
 - Stands
 - Pedals
 - Keep small items out of the reach of children. To prevent accidental ingestion of the parts listed below, always keep them out of the reach of small children.
 - Included Parts:
 - Cable clip
 - Cable tie
 - Wing bolts
 - Drum key
 - Removable Parts:
 - Screws
 - Washers
 - Nuts
 - Felt washers
 - Springs
 - Hand knobs
 - Protective cap for dedicated connection cable

IMPORTANT NOTES

- Additional Precautions**
- Use a reasonable amount of care when using the unit's sensors; and when using its jacks and connectors. Rough handling can lead to malfunctions.
 - This instrument is designed to minimize the extraneous sounds produced when it's played. However, since sound vibrations can be transmitted through floors and walls to a greater degree than expected, take care not to allow these sounds to become a nuisance to others nearby.
 - This document explains the specifications of the product at the time that the document was issued. For the latest information, refer to the Roland website.
- Intellectual Property Right**
- It is forbidden by law to make an audio recording, video recording, copy or revision of a third party's copyrighted work (musical work, video work, broadcast, live performance, or other work), whether in whole or in part, and distribute, sell, lease, perform, or broadcast it without the permission of the copyright owner.
 - Do not use this product for purposes that could infringe on a copyright held by a third party. We assume no responsibility whatsoever with regard to any infringements of third-party copyrights arising through your use of this product.
 - The copyright of content in this product (the sound waveform data, style data, accompaniment patterns, phrase data, audio loops and image data) is reserved by Roland Corporation.
 - Purchasers of this product are permitted to utilize said content (except song data such as Demo Songs) for the creating, performing, recording and distributing original musical works.
 - Purchasers of this product are NOT permitted to extract said content in original or modified form, for the purpose of distributing recorded medium of said content or making them available on a computer network.
 - The SD logo and SDHC logo are trademarks of SD-3C, LLC.
 - ASIO is a trademark and software of Steinberg Media Technologies GmbH.
 - This product contains eParts integrated software platform of eSOL Co., Ltd. eParts is a trademark of eSOL Co., Ltd. in Japan.
- Bluetooth®** word mark and logos are registered trademarks owned by Bluetooth SIG, Inc. and any use of such marks by Roland is under license.
- This Product uses the Source Code of µT-Kernel under T-License 2.0 granted by the T-Engine Forum (www.tron.org).
- Roland, BOSS, and V-Drums are either registered trademarks or trademarks of Roland Corporation in the United States and/or other countries.
- Company names and product names appearing in this document are registered trademarks or trademarks of their respective owners.