

# USER MANUAL MANUALE D'USO

**VSA 2050 II**  
**VSA 1250 II**  
**VSA 850 II**

- DIGITALLY STEERABLE ARRAY  
SPEAKER SYSTEMS
- DIFFUSORI ATTIVI DIGITALI  
DI TIPO "ARRAY"



**IMPORTANT**

Before connecting and using this product, please read this instruction manual carefully and keep it on hand for future reference.

The manual is to be considered an integral part of this product and must accompany it when it changes ownership as a reference for correct installation and use as well as for the safety precautions.

**RCF S.p.A.** will not assume any responsibility for the incorrect installation and / or use of this product.

**WARNING:** To prevent the risk of fire or electric shock, never expose this product to rain or humidity.

This device is intended for indoor use only.

**SAFETY PRECAUTIONS**

**1.** All the precautions, in particular the safety ones, must be read with special attention, as they provide important information.

**2.1 - PRIMARY POWER SUPPLY FROM MAINS**

- The mains voltage is sufficiently high to involve a risk of electrocution: never install or connect this product when its power cord is plugged in.
- Before powering up, make sure that all the connections have been made correctly and the voltage of your mains corresponds to the voltage shown on the rating plate on the unit, if not, please contact your RCF dealer.
- The metallic parts of the unit are earthed by means of the power cord.  
An apparatus with CLASS I construction shall be connected to a mains socket outlet with a protective earthing connection.
- Protect the power cord from damage. Make sure it is positioned in a way that it cannot be stepped on or crushed by objects.
- To prevent the risk of electric shock, never open this product: there are no parts inside that the user needs to access.

**2.2 - 24 V dc SECONDARY POWER SUPPLY BY BATTERIES**

- The apparatus operating voltage is 24 V dc, therefore it is necessary to connect in series several batteries having a lower nominal voltage, example: 2 x 12 V.
- Always use rechargeable batteries, which need to be chosen according to the maximum possible load.
- Verify the polarity of batteries is correct.
- Do NOT short-circuit batteries (i.e. connecting the 2 opposite poles together with metallic wires).
- Throw empty batteries away according to your country laws about ecology and environment protection.

**3.** Make sure that no objects or liquids can get into this product, as this may cause a short circuit.

This apparatus shall not be exposed to dripping or splashing. No objects filled with liquid (such as vases) and no naked sources (such as lit candles) should be placed on this apparatus.

**4.** Never attempt to carry out any operations, modifications or repairs that are not expressly described in this manual.

Contact your authorized service centre or qualified personnel should any of the following occur:

- The product does not function (or functions in an anomalous way).
- The power cord has been damaged.
- Objects or liquids are inside the product.
- The product has been subject to a heavy impact.

**IMPORTANT****WARNING**

5. If this product is not used for a long period, disconnect its power cord and / or batteries.

6. If this product begins emitting any strange smell or smoke, **switch it off immediately and disconnect its power cord.**

7. Do not connect this product to any equipment or accessories not foreseen.

For suspended installation, only use the dedicated anchoring points and do not try to hang this product by using elements that are unsuitable or not specific for this purpose.

Also check the suitability of the support surface to which the product is anchored (wall, ceiling, structure, etc.), and the components used for attachment (screw anchors, screws, brackets not supplied by RCF etc.), which must guarantee the security of the system / installation over time, also considering, for example, the mechanical vibrations normally generated by transducers.

To prevent the risk of falling equipment, do not stack multiple units of this product unless this possibility is specified in the user manual.

**8. RCF S.p.A. strongly recommends this product is only installed by professional qualified installers (or specialised firms) who can ensure correct installation and certify it according to the regulations in force.**

**The entire audio system must comply with the current standards and regulations regarding electrical systems.**

9. Supports and trolleys

The equipment should be only used on trolleys or supports, where necessary, that are recommended by the manufacturer. The equipment / support / trolley assembly must be moved with extreme caution.

Sudden stops, excessive pushing force and uneven floors may cause the assembly to overturn.

10. Mechanical and electrical factors need to be considered when installing a professional audio system (in addition to those which are strictly acoustic, such as sound pressure, angles of coverage, frequency response, etc.).

11. Hearing loss

Exposure to high sound levels can cause permanent hearing loss. The acoustic pressure level that leads to hearing loss is different from person to person and depends on the duration of exposure. To prevent potentially dangerous exposure to high levels of acoustic pressure, anyone who is exposed to these levels should use adequate protection devices.

When a transducer capable of producing high sound levels is being used, it is therefore necessary to wear ear plugs or protective earphones.

See the manual technical specifications to know the maximum sound pressure level.

12. Situate this product far from any heat sources and always ensure adequate air circulation around it.

13. Do not overload this product for a long time.

14. Never force the control elements (keys, knobs, etc. ).

15. Do not use solvents, alcohol, benzene or other volatile substances for cleaning the external parts of this product.

Use a dry cloth.

#### **NOTES ABOUT AUDIO SIGNAL CABLES**

To prevent the occurrence of noise on microphone / line signal cables, use screened cables only and avoid putting them close to:

- Equipment that produces high-intensity electromagnetic fields.
- Mains cables.
- Loudspeaker lines.

RCF S.P.A. THANKS YOU FOR PURCHASING THIS PRODUCT, WHICH HAS BEEN DESIGNED TO GUARANTEE RELIABILITY AND HIGH PERFORMANCES.

## DESCRIPTION



VSA II series is made of multi-amplified vertical steerable arrays that represent one of the latest RCF applications in terms of digital audio technology.

The 3 available models have similar features, but:

- **VSA 2050 II** is the top model and includes 20 amplifiers and 20 full-range 3.5" RCF transducers, its vertical dispersion is controlled up to 10° from 150 Hz and up.
- **VSA 1250 II** includes 12 amplifiers and 12 full-range 3.5" RCF transducers, its vertical dispersion is controlled up to 10° from 300 Hz and up.
- **VSA 850 II** includes 8 amplifiers and 8 full-range 3.5" RCF transducers, its vertical dispersion is controlled up to 10° from 500 Hz and up.

The internal digital signal processor processes the audio signal sent to each single internal transducer in order to control the overall vertical acoustic dispersion.

VSA II series speakers are the ideal for indoor installations, where a critical acoustic environment can be an issue and a moderate visual impact is required, for instance: houses of worship, airports, railway stations, auditoriums, congress halls, sport halls, shopping malls, etc. .

Unlike traditional sound columns, VSA speaker calibration is carried out electronically via either RdNet software or its VSA SMART RC remote control for smartphones (to be purchased separately and necessary, as it also includes the USB / RS 485 cable adapter with RJ45 connector for linking to a computer), by specifying the installation height above the floor and the listening area (or the maximum distance from speakers to audience).

The signal is fully processed and amplified in the digital domain, thanks also to 6 FPGAs ('Field Programmable Gate Array') that manage all the data inside the speaker system.

The circuitry is modular to get maximum reliability and easy servicing.

VSA II speakers include 2 independent power supply units, controlled by a microprocessor for either AC (230 / 115 V) or DC (24 V) operation, to get full back-up facility when the product is intended for emergency purposes.

Each internal circuit is monitored (voltage, current and temperature).

VSA II series speakers meet all requirements needed by sound systems for emergency purposes.

One of the most important feature of the VSA digital arrays is their simple configuration, thanks to RdNet software or its VSA SMART RC remote control for smartphones.

In a few steps, it is possible to tilt down and shape the acoustic beam in a virtual way, while the column speaker is installed in a physical vertical position.

This configurability permits to address the audio signal exactly to the listening area, avoiding to send acoustic energy to ceilings and empty floors, thus not introducing additional bad reflections that would affect speech intelligibility, mainly in critical environments with high reverberation time.

20 'class D' amplifiers (50 W each, with high capacity power supply) for the VSA 2050 II model, 12 for VSA 1250 II and 8 for VSA 850 II, assure the best possible control and dynamics.

Each cabinet has four LEDs (AC, DC, FAULT and PRIORITY) and provides dry contacts (of an internal relay) for remote 'fault' indication.

Thanks to a sophisticated algorithm developed by RCF, the focus control is not strictly necessary as the best possible result is guaranteed overall the covered listening areas.

It is possible to set the acoustical coverage (tilt and beam) according to installation height and the listening area to be served.

Each speaker has 2 audio inputs, of which one has priority.

VSA II speakers can be installed very close to the wall (to be unobtrusive) thanks to their compact sizes, slim shapes and their (included) wall mounting accessories.

**SWM-BR VSA II** optional accessory: each kit includes a pair of swivel brackets for a single VSA II speaker wall mounting, allowing a horizontal angle pointing up to 60°.

Connections are separated: AC and DC power supply at one end, audio signals and interfaces on the other. The electrical connections are clearly labelled and made through screw terminals and other suitable and easy-to-wire connectors.

VSA II series (standard version) is intended for indoor sound systems only.

## INSTALLATION



The speaker shall be wall-mounted through the two included brackets (picture 1).

TO SWIVEL IT WITH A HORIZONTAL ANGLE UP TO 60°, IT IS NECESSARY TO PURCHASE THE OPTIONAL **SWM-BR VSA II** ACCESSORY KIT.

**Minimum installation height: the speaker bottom shall be at least 1 m from the floor (suggested height: from 1.5 to 3 m).**

THE WOOD PACKAGE LID CAN ALSO BE USED AS DRILLING TEMPLATE (PICTURE 2)!

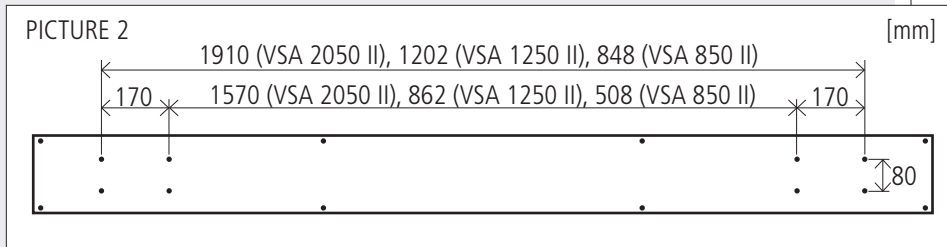

Each bracket shall be fixed to the wall by 4 dowels for 5 mm screws (passing through the 4 holes, see picture 3 – **A**).

If put to recessed pipelines, the power cables (230-115 V ac and, separately, 24 V dc) can pass through the bracket and the loudspeaker holes (picture 3 – **B**).

Put the speaker on the bracket hooks and fix it with the security screws (picture 3 – **C**), which prevent the speaker might accidentally slip off and fall.

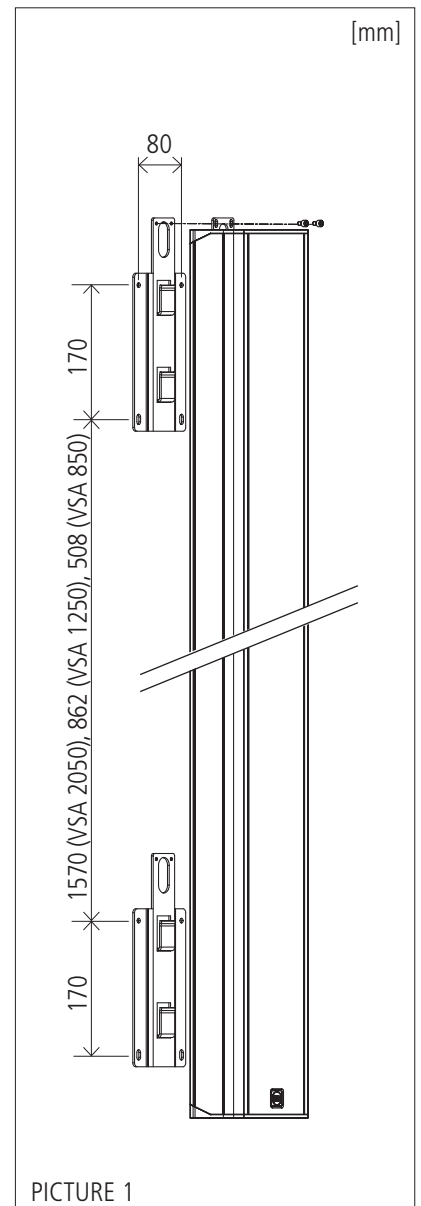
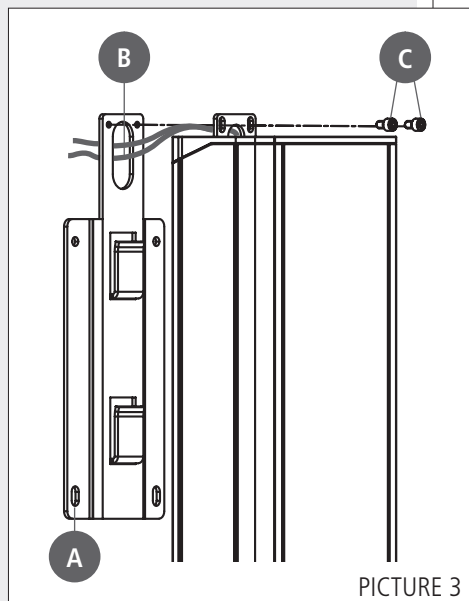

## TOP PANEL (power supply)

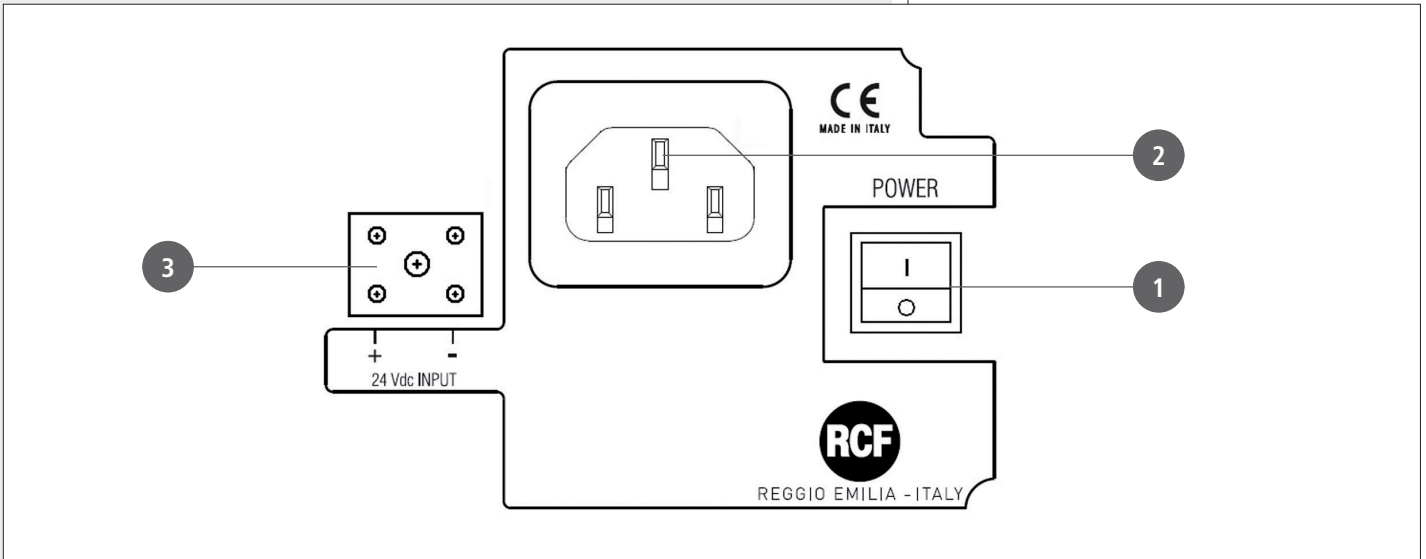

- 1 POWER**  
Main power switch.  
I : ON      O : OFF

AFTER TURNING THE SPEAKER ON, THE SYSTEM TAKES ABOUT 15 SECONDS ('START-UP') TO GET FULLY OPERATING.

- 2** Socket for the power cord.  
Before powering up, make sure the mains voltage corresponds to the voltage indicated on the unit label.
- 3 24 Vdc INPUT**  
Secondary power supply input (24 V dc).



## BOTTOM PANEL (signals and commands)



Remove the bottom panel cover with the 4 LEDs to access to connections (by disconnecting its cable from the respective port **10**).

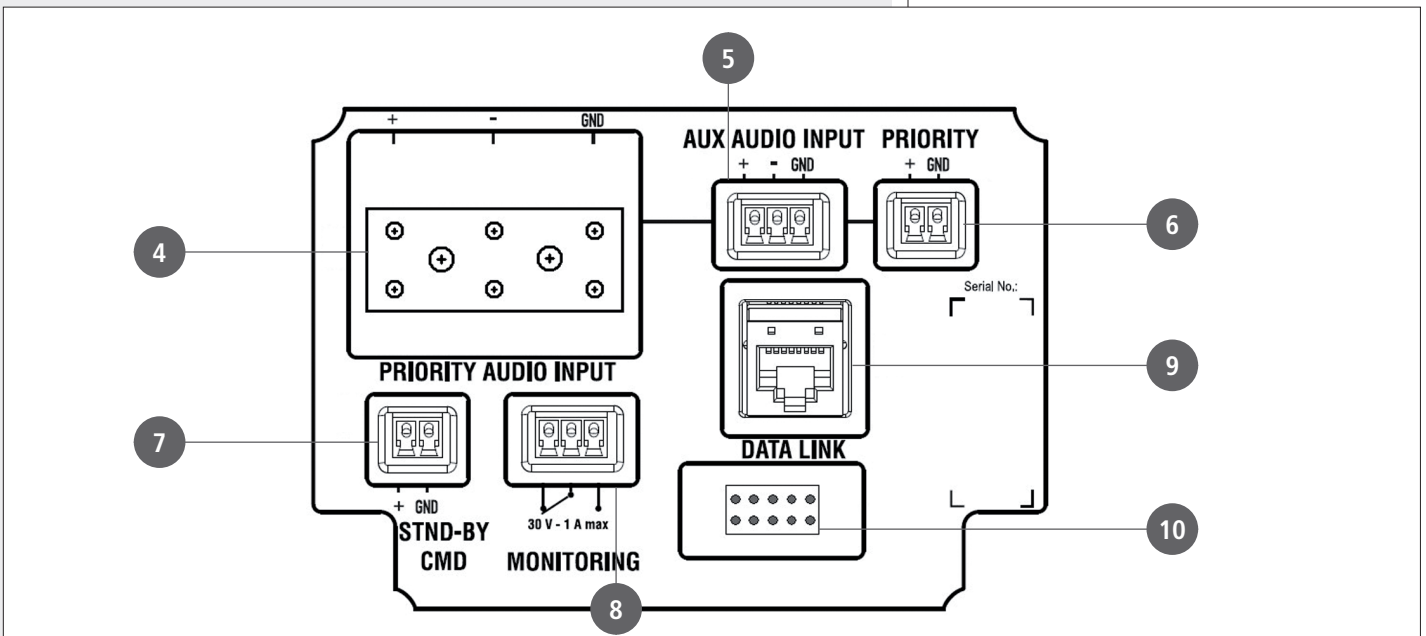

**4 PRIORITY AUDIO INPUT**

Main audio input that can be enabled by the remote control or the PRIORITY **6** command.

The ceramic terminal allows its use in sound systems for emergency purposes.  
+ (hot) signal, – (cold) signal, GND ground

**5 AUX AUDIO INPUT**

Auxiliary audio input (with removable plug) that can be enabled by the remote control.  
+ (hot) signal, – (cold) signal, GND ground

ONLY AN AUDIO INPUT CAN BE OPEN AT A TIME. IT IS NOT POSSIBLE TO MIX 2 INPUT SIGNALS.

**6 PRIORITY**

Priority command input, activated when the + and GND pins are short-circuited. The priority function is mainly for emergency: when activated, the PRIORITY AUDIO INPUT **4** gets open (the aux input gets muted) regardless the remote control settings, the speaker is forced on if the stand-by command **7** is present, the volume is set to its maximum level.

**7 STND-BY CMD**

Stand-by command input, activated when the + and GND pins are short-circuited. It has no effect if the PRIORITY **6** command is present.

THE SPEAKER HAS ALSO AN AUTOMATIC STAND-BY MODE AFTER CA. 30 MINUTES WITHOUT DETECTING ANY AUDIO SIGNAL. WHEN IN AUTOMATIC STAND-BY MODE, THE SPEAKER WILL AUTOMATICALLY TURN ON AS SOON AS AN AUDIO SIGNAL IS DETECTED ON THE SELECTED INPUT.

**8 MONITORING**

Dry contacts (normally-closed, common, normally-open) of an internal relay that can be used for 'faulty' remote indication.

This relay is activated when the speaker is working properly.

During any fault (or the speaker is switched off), the relay is deactivated.

Max. current applicable on contacts: 1 A. Max. voltage applicable on contacts: 30 V.

**9 DATA LINK**

RJ 45 port to link to a computer USB port for configuration via RdNet software (the cable is included in the VSA SMART RC kit).

The standard is RS 485:

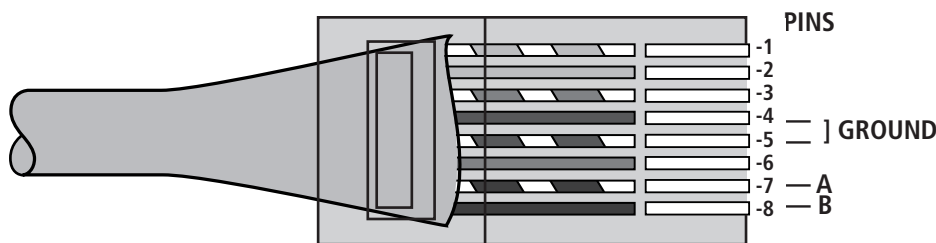

- 1. Orange/White
- 2. Orange
- 3. Green/White
- 4. Blue
- 5. Blue/White
- 6. Green
- 7. Brown/White
- 8. Brown

**10** Port to connect the bottom panel cover with the 4 LEDs.

## LEDS ON THE BOTTOM PANEL COVER

DURING THE SPEAKER START-UP (AFTER SWITCHING ON, CA. 15 SECONDS) ALL THE 4 LEDS ARE FLASHING.

From left to right:

### 1 AC (green)

When lit: AC power supply (mains: 230 / 115 V) is present and the speaker is operating.

### 2 DC (green)

When lit: 24 V DC power supply is present and the speaker is operating.

If batteries are not connected (or not available) or the voltage is lower than the minimum threshold, this LED will be off.

IF BOTH **AC** AND **DC** LEDS (ONLY) ARE FLASHING, THE SPEAKER IS IN STAND-BY MODE.

### 3 FAULT (yellow)

When lit: a fault has been detected.

### 4 PRIORITY (red)

When lit: the priority function (of the PRIORITY AUDIO INPUT ) is activated by the respective contact .



## LEDS ON THE BOTTOM PANEL COVER



## NOTES ABOUT THE RDNET SOFTWARE



The **RDNET** software is protected by international copyright laws and is to be used to configure the **RCF RDNET** system devices only.

It is not allowed to modify or change or try to decompile this software.

In no event shall RCF S.p.A. be liable to end-users for any damage whatsoever, including but not limited to financial damages for loss of business profits or business information due to the software use or inability to use this product.

The foregoing provision is effective even if RCF S.p.A. has been advised of the possibility of such damages.

Even if the SOFTWARE has any material, verifiable and reproducible program errors, RCF S.p.A. shall have no obligation to modify such errors.

## RDNET SOFTWARE INSTALLATION



**MINIMUM REQUIREMENT:** A PC WITH EITHER MICROSOFT 'WINDOWS® VISTA' OR '7' (OR LATER) OPERATING SYSTEM, HAVING AN AVAILABLE USB PORT.



Before installing a new software release, it is necessary to remove the previous version (if installed). Verify also that the new release is the right one for the PC operating system: either 32-bit or 64-bit.

Run rcf\_rdnetssetup\_(version).exe to start the setup wizard.

Click **NEXT >** to proceed.





Read the license agreement.  
Click 'I Agree' to accept and proceed with the software installation.

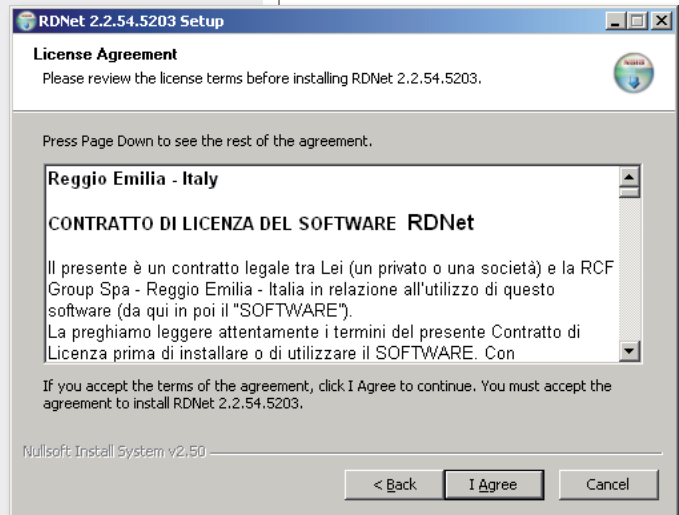

It is now possible to change the installation folder (directory) of the RDNET software (or keep the default path).

Click INSTALL to proceed.

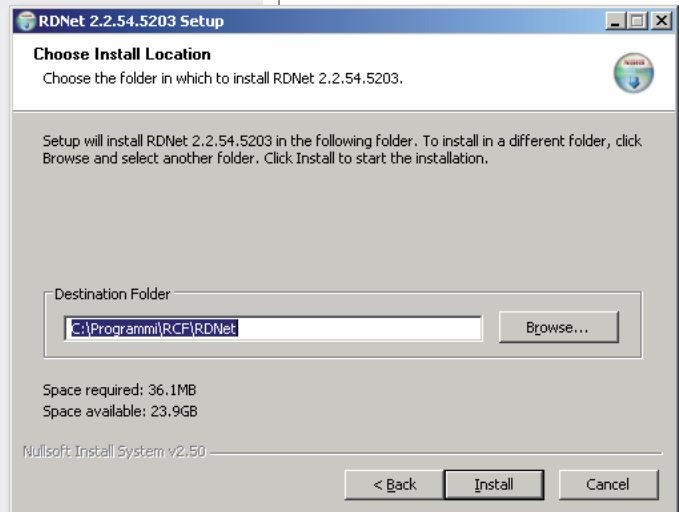

As soon as the installation ends, it will be necessary to reboot your computer.  
Choose either 'Reboot Now' to reboot immediately or 'I want to reboot later' to reboot later manually.

Click FINISH to quit.

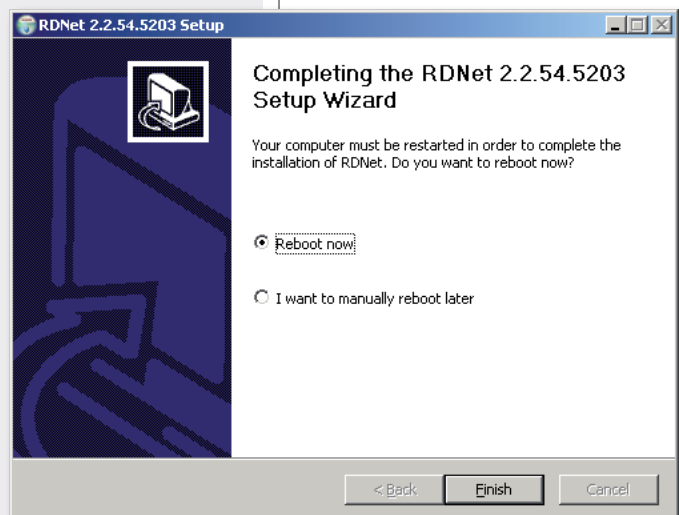



Link the computer USB port to the VSA speaker DATA LINK <sup>9</sup> input by using the cable included in the VSA SMART RC kit.

Run the RDNET software (in Windows, click):

**Start > Programs > RCF > RDNNet > RDNNet**  
(or double-click **RDNNet** icon on the desktop).

First, in the main menu, click '**Go**' and then '**Controllers**'.

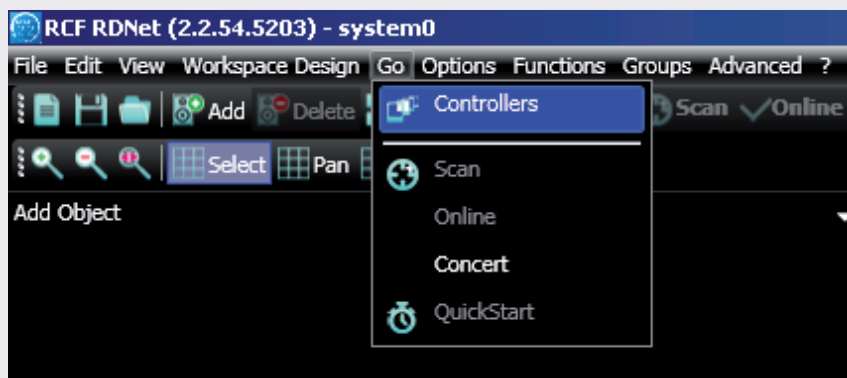

In the '**Controllers**' section (bottom left in the main window), click '**Match All**' (or click each single 'Match' button or simply drag and drop) to add all linked USB devices (COM) to the '**Workspace Controllers**' list (bottom right in the main window).

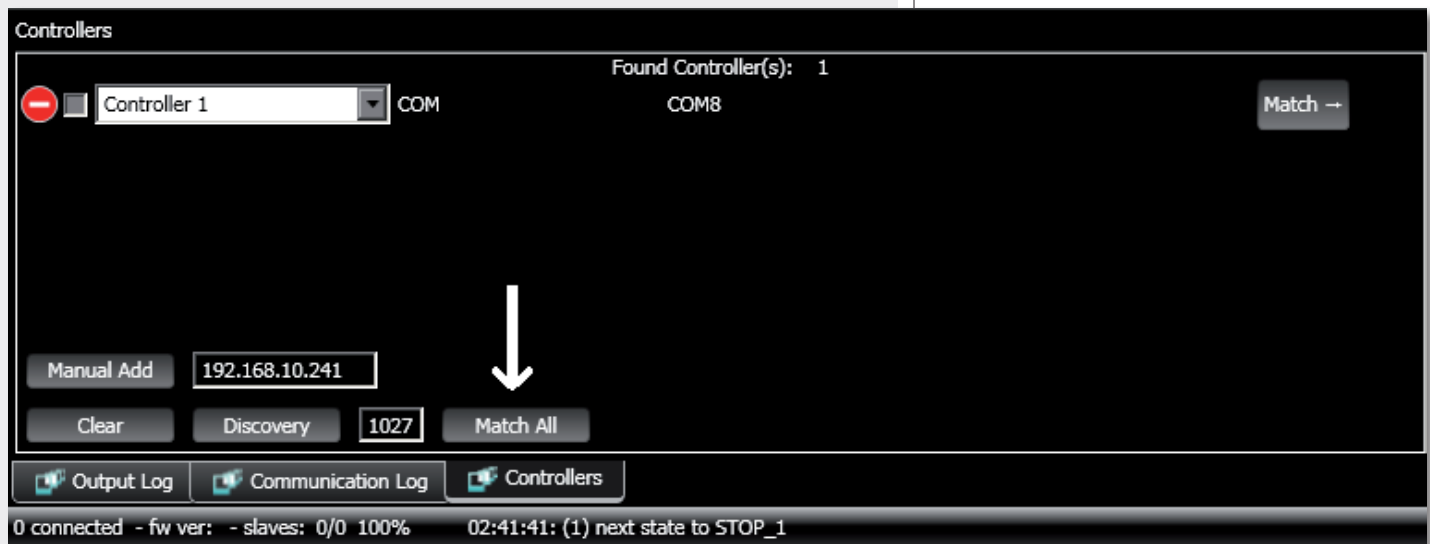

In the main menu, now click 'Quickstart': in the bottom right-hand corner of the main window (in the bottom bar) the word 'OFFLINE' becomes 'ONLINE'.

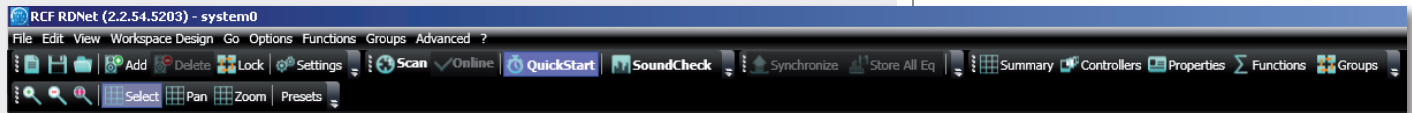

The detected VSA speaker module now appears (e.g. VSA 2050).

The '✓' symbol (on green background) indicates that the VSA speaker has been properly connected (while the '—' symbol on red background indicates 'not detected' / 'not present').

To open and edit the VSA setup window, point the PC mouse on the VSA module and double-click (or right-click and select 'Show Obj Details')

To upgrade the VSA speaker firmware (main menu: "Advanced > Firmware Upgrade..."). Refer to the RDNET user manual for all software functions.

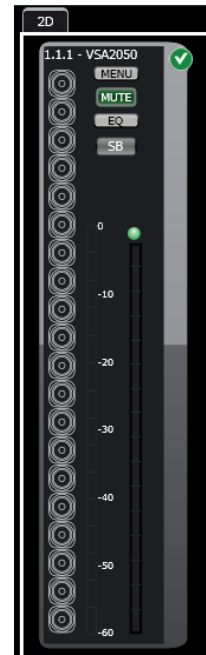
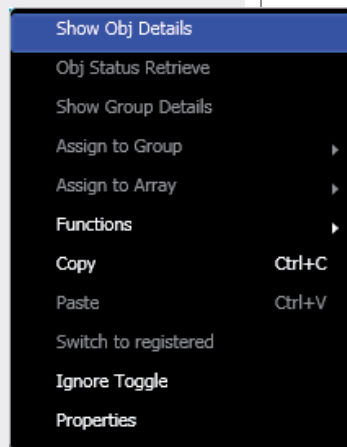

## SETUP WINDOW

### MUTE

Click MUTE to mute the VSA speaker (all MUTE buttons get red). Click MUTE again to unmute.

### SOLO

This function is useful only when an RdNet network with several speakers is present (through either a RDNET CONTROL 8 or CONTROL 2 device). Read the RdNet software user manual.

Click SOLO to make the selected VSA speaker the only one activated, while the others are muted.

### STANDBY

Stand-by mode.

### M1 to M20 buttons (on the left).

VSA test mode that allows to listen to each single transducer.

Click one of the **M1 – M20** buttons (relative to each single transducer) for solo listening.

Click either it again to reset the normal operation or another one to keep testing.

Green: unmuted, red: muted.

**EQ:** click EQ to open and edit the equalizer window (relative to the three custom equalizations), which includes both **Gain** and **Delay** settings as well.

**BEAM:** click BEAM to open and edit the beam setting window.

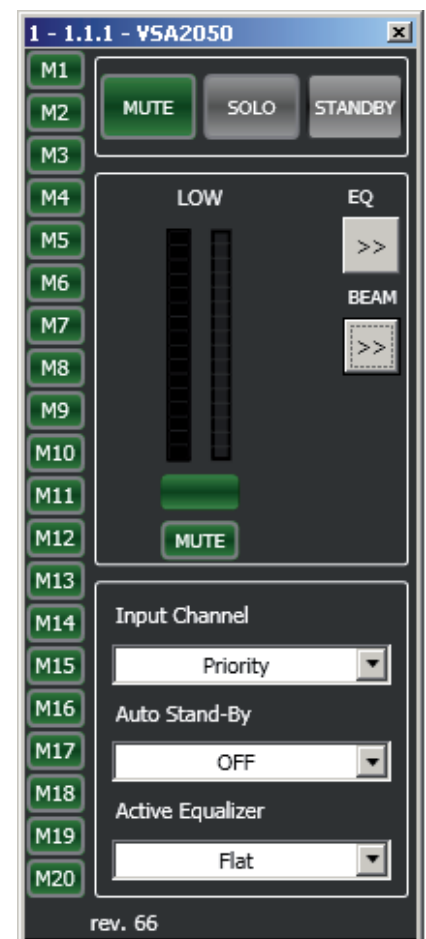

### INPUT CHANNEL

Input channel selection:

- **PRIORITY**                    **PRIORITY AUDIO INPUT** is open  
(AUX AUDIO INPUT is muted).
- **AUXILIARY**                    **AUX AUDIO INPUT** is open  
(PRIORITY AUDIO INPUT is muted).

THE AUXILIARY SELECTION HAS NO EFFECT WHEN THE PRIORITY FUNCTION OF THE PRIORITY AUDIO INPUT IS ACTIVATED.

### AUTO STAND-BY

If set to **25 Min**, VSA speakers will automatically turn off (stand-by) after 25 minutes without detecting any audio signal and turn on as soon as an audio signal is detected on the selected input (or due to the activation of the priority function).

Set AUTO STAND-BY to **OFF** to disable this function.

### ACTIVE EQUALIZER

The equalization can be chosen among 6 different settings: 3 are presets and 3 are editable by the user (custom 1, 2, 3).

- **FLAT**                            no equalization (flat frequency response)
- **SPEECH**                      equalization optimized for speech
- **MUSIC**                        equalization optimized for music
- **CUSTOM 1 – 2 – 3**          3 custom equalizations by setting max. 8 filters

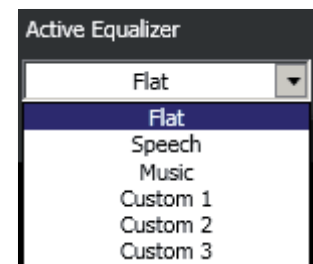
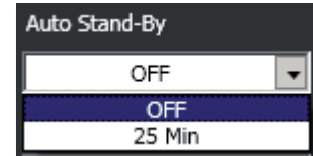

## BEAM SETTING WINDOW

Click BEAM to open and edit the beam setting window.

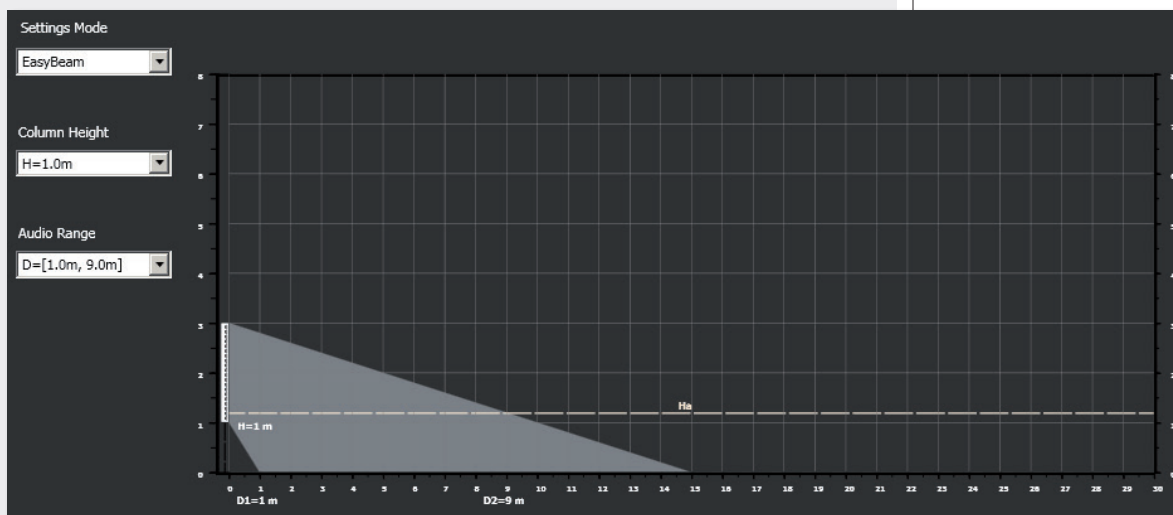

Values represented graphically:

- **H**: speaker bottom installation height
- **Ha**: considered listening area height (1.2 m)
- In **EASY BEAM** mode, the minimum **D1** and maximum **D2** distances of the listening area from the speaker
- In **EASY FOCUS** mode, the maximum distance **F** to be covered
- In **FREE BEAM** mode, the tilt **T** (vertical angle downwards) and the beam **B** (vertical dispersion).

### 1. First, select the **SETTINGS MODE**:

- **EASY BEAM** allows to specify the listening area to be covered by selecting a preset audio range.
- **EASY FOCUS**, simple, easy and suitable for all systems, advisable for users and installers that are not so expert. Only two values are necessary: the speaker installation height and the maximum distance to be covered.
- **FREE BEAM**, for expert users / installers, it allows the (virtual) setting of both speaker tilt and beam.

### 2. Set the speaker installation height (considering the distance from its bottom to the floor) by clicking **COLUMN HEIGHT**.

The range is from 1 to 6 metres (0.1 m steps) in the EASY BEAM mode, from 1.5 to 3 metres (0.5 m steps) in the EASY FOCUS mode, from 2 to 6 metres (0.1 m steps) in the FREE BEAM mode.

### 3a. (EASY BEAM) Set the listening area **D** through **AUDIO RANGE**.

Both minimum D1 and maximum D2 distances (from speaker) can be selected among several presets according to the speaker height H.

### 3b. (EASY FOCUS) Set the maximum distance to be covered through FOCUS.

### 3c. (FREE BEAM) Set the **TILT** and then the **BEAM**.

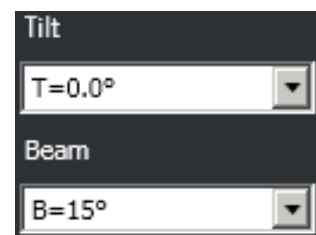
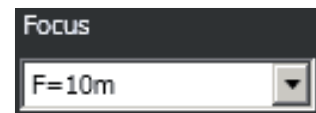
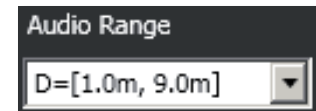
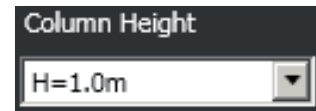
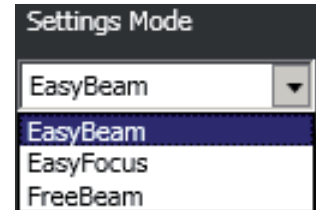



Click EQ to open and edit the equalizer window (relative to the three custom equalizations), which includes both **Gain** and **Delay** settings as well.

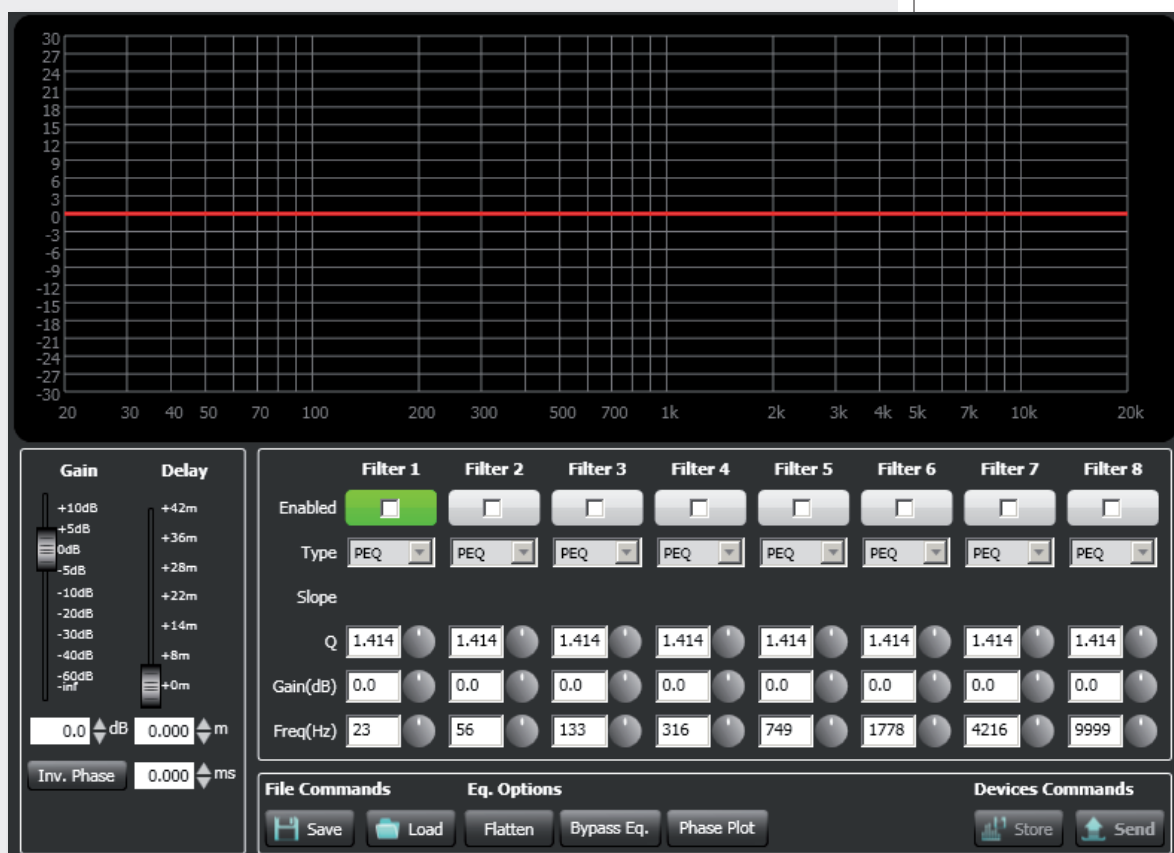

First, in the **Active Equalizer** option menu, choose one of the three custom equalizations **CUSTOM 1 – 2 – 3** to edit.

It is possible to set up to eight independent filters (Filter 1, 2, 3, 4, 5, 6, 7, 8).

**Enabled:** click the checkbox to toggle each filter.

Move the mouse on its white background (making it green) to highlight a filter (if present) on the EQ graph.

**Type:**

- **DISABLED:** the filter is disabled (by-pass).
- **PEQ:** parametric equalizer that allows to adjust the level at the settable centre frequency and specify the Q factor (the adjusted level can be widened or narrowed).
- **SHELVING HIGH:** increase or decrease the level of all frequencies above the selected frequency by the specified amount.
- **SHELVING LOW:** increase or decrease the level of all frequencies below the selected frequency by the specified amount.
- The **BUTTERWORTH, LINKWITZ-RILEY, BESSEL** options are only available for the filters no.1 ('high-pass') and no.8 ('low-pass').

**Slope:** filter slope setting (dB / oct).

**Q:** Q factor setting.

**Gain (dB):** filter gain setting.

**Freq (Hz):** either filter frequency selection or PEQ central frequency setting.

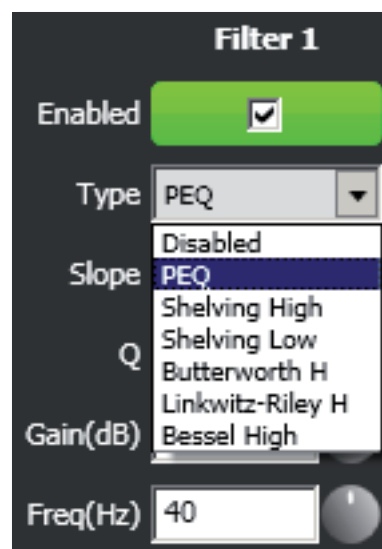
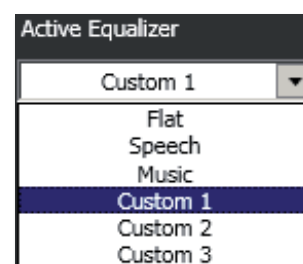

**File Commands:**

- **SAVE:** it saves to PC the current equalization as .rde file.
- **LOAD:** it loads from PC an equalization previously saved as .rde file.

**Eq. options:**

- **FLATTEN:** it disables all filters (flat frequency response).
- **BYPASS EQ.:** it disables the equalization, but without changing filter settings.
- **PHASE PLOT:** if selected, the phase plot is shown (green line).

**Devices commands:**

- **STORE:** it sends and stores the equalization to the VSA speaker.
- **SEND:** it sends (without storing) the equalization to the VSA speaker.

For each filter, frequency and gain can be adjusted either graphically (through the mouse) by dragging the little coloured square or in an analytical way (by inserting values in cells or rotating controls).

The overall equalization is shown as a red line, the intervention of the selected filter as a green line, the intervention of a filter that is not selected as a white line.

For example, to apply a 12 dB attenuation for frequencies below 80 Hz: enable the filter 1 by clicking its 'Enabled' checkbox, select the SHELIVING LOW filter type, set the gain to -12 dB and frequency to 80 Hz .

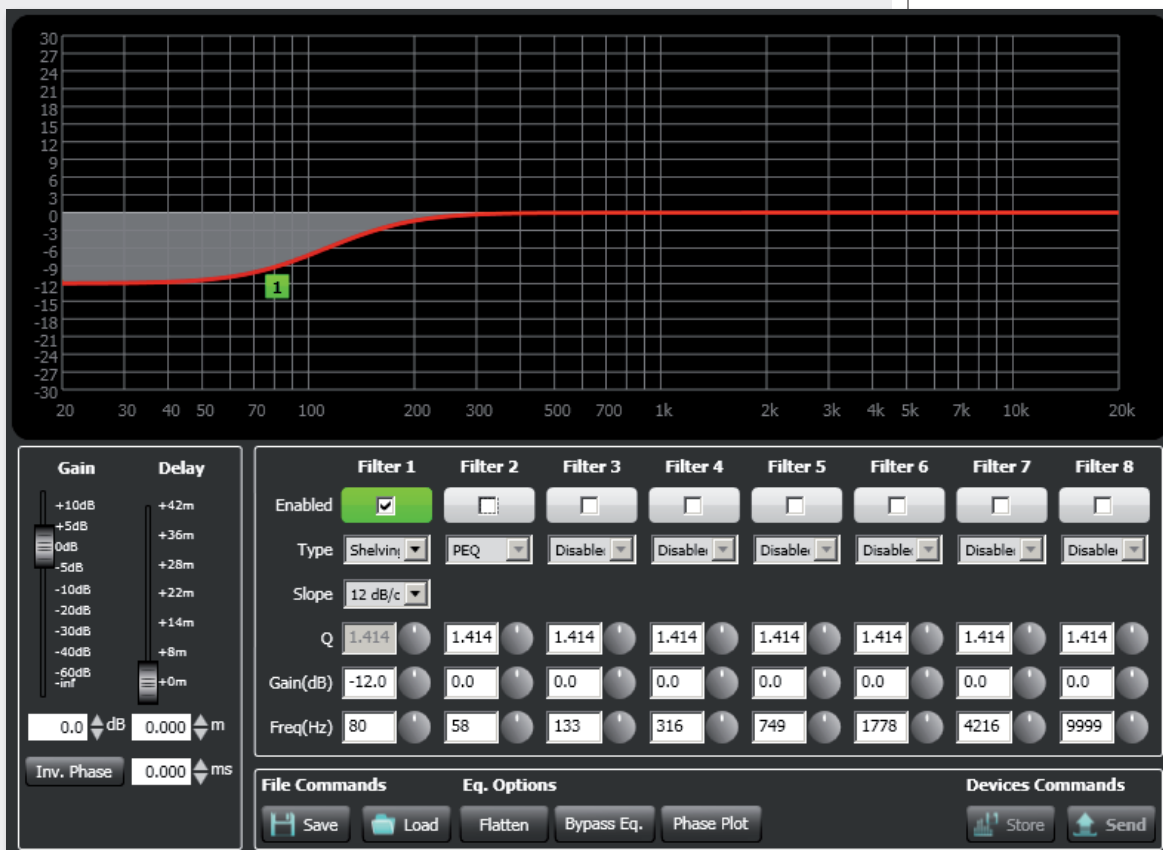

To add a second filter (i.e. PEQ): enable the filter 2, select the PEQ filter type, its gain and central frequency, then set its Q factor.

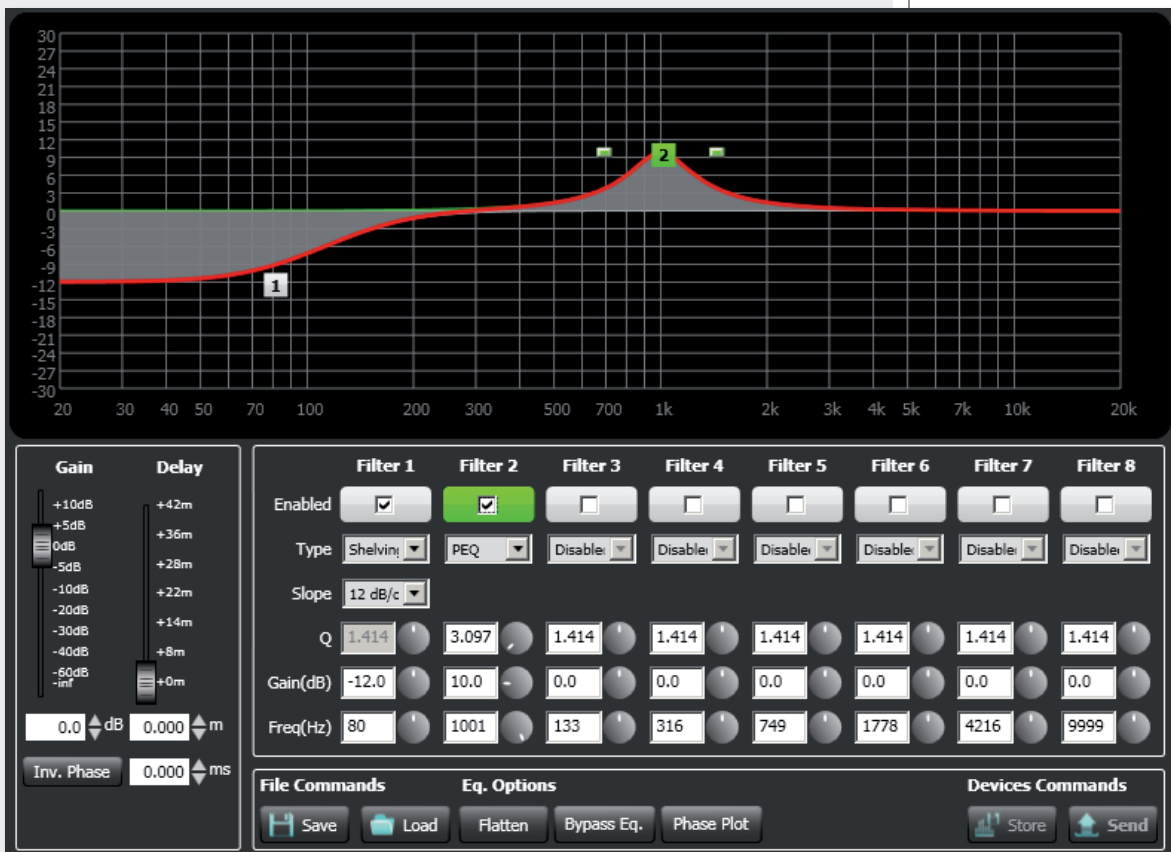

Finally, click either **STORE** (send and store) or **SEND** all EQ settings (without storing) to the VSA speaker.

**GAIN**

Gain setting (dB) of all the audio range (0 = flat).

**DELAY**

Delay line setting.

If the sound system is made of two or more speaker lines, it is advisable to delay the sound from the second line onwards (setting a delay time directly proportional to the distance from the first speaker line), in order to reduce the perception of echo (due to the different reception times of sounds coming from speakers that are distant one another), give a correct sense of depth to listeners and improve the speech intelligibility.

You can set the distance in meters (graphically or analytically) or the time in milliseconds (by entering the numeric value only).

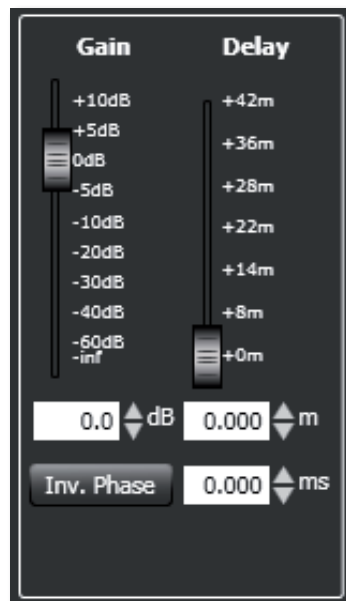

EXAMPLE (SEE THE FIGURE):

- The B SPEAKER IS 15 METRES FAR FROM THE A SPEAKER (FIRST LINE) AND NEEDS TO BE DELAYED BY SETTING THE DELAY PARAMETER TO **15 m**.



- The C SPEAKER IS 30 METRES FAR FROM THE A SPEAKER (FIRST LINE) AND NEEDS TO BE DELAYED BY SETTING THE DELAY PARAMETER TO **30 m**.

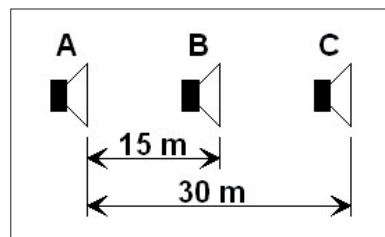

**INV. PHASE**

If selected (red light), the VSA speaker phase is inverted.





	VSA 2050 II	VSA 1250 II	VSA 850 II	
<b>ACOUSTICAL SPECS.</b>				
Frequency response	100 Hz ÷ 18 kHz	120 Hz ÷ 18 kHz	130 Hz ÷ 18 kHz	
Max. sound pressure level (A-weighted at 30 m)	96 dB	94 dB	93 dB	
Horizontal coverage angle	130°	130°	130°	
Vertical coverage angle	selectable from 10° to 30°	selectable from 10° to 30°	selectable from 10° to 30°	
Vertical steering angle	selectable from 0° to -40°	selectable from 0° to -40°	selectable from 0° to -40°	
Transducers	20 x 3.5" full-range loudspeakers	12 x 3.5" full-range loudspeakers	8 x 3.5" full-range loudspeakers	
<b>INPUT SECTION</b>				
Input sensitivity	0 dBu			
Connectors	balanced screw terminals balanced ceramic screw terminal			
Controls	remote control infrared port priority command remote 'fault' indication stand-by remote command			
LEDs	Power supply, fault, priority			
<b>PROCESSOR</b>				
Type	Texas TMS320C6726 32-bit floating point DSP Spartan3A FPGA 24 bit AD converters, 48 kHz			
Operation	20 PEQ channels, compression, beam forming, 20 limiters and protections			
<b>AMPLIFIERS</b>				
Type	20 'class D' amplifiers	12 'class D' amplifiers	8 'class D' amplifiers	
Power (each amplifier)	50 W	50 W	50 W	
<b>POWER SUPPLY</b>				
AC power supply	either 230 V or 115 V (according to the model), 50 – 60 Hz, type: 'switching'			
Consumption	stand-by	26 W	21 W	18 W
	operating, no signal	66 W	46 W	36 W
	max. power	600 W	600 W	400 W
Internal fuse (AC)	T3.15AL/250 V (230 V); T6.3AL/250 V (115V)			
Secondary DC power supply	24 V			
DC power in connector	ceramic screw terminal			
<b>PHYSICAL SPECS.</b>				
Cabinet material	aluminium (powder coated)			
Dimensions (w, h, d)	125, 2070, 97 mm	125, 1340, 97 mm	125, 980, 97 mm	
Net weight	19 kg	14 kg	10 kg	
Colour	RAL 9003 (white)			
<b>INCLUDED ACCESSORIES</b>				
Installation	2 wall-mounting brackets			
<b>REQUIRED ACCESSORY TO BE PURCHASED SEPARATELY</b>				
Remote control for smartphone with the USB / RS 485 cable to link to PC	VSA SMART RC			
<b>OPTIONAL ACCESSORY</b>				
Installation with a horizontal angle up to 60°	SWM-BR VSA II			

Salvo eventuali errori ed omissioni.  
RCF S.p.A. si riserva il diritto di apportare modifiche senza preavviso.

Except possible errors and omissions.  
RCF S.p.A. reserves the right to make modifications without prior notice.

[www.rcf.it](http://www.rcf.it)



**RCF S.p.A.** Italy  
Via Raffaello Sanzio, 13  
42124 Reggio Emilia - Italy  
Tel +39 0522 274 411  
Fax +39 0522 232 428  
e-mail: [info@rcf.it](mailto:info@rcf.it)